



IF PARTS ARE MISSING AND OR DEFECTIVE, IF INSTRUCTIONS ARE NOT CLEAR  
OR IF YOU ARE EXPERIENCING PROBLEMS ASSEMBLING OUR PRODUCT.

**BEFORE YOU RETURN THE PRODUCT TO THE STORE,  
PLEASE CALL US TOLL FREE FOR CUSTOMER SERVICE ASSISTANCE**

**(888) 777-8250**







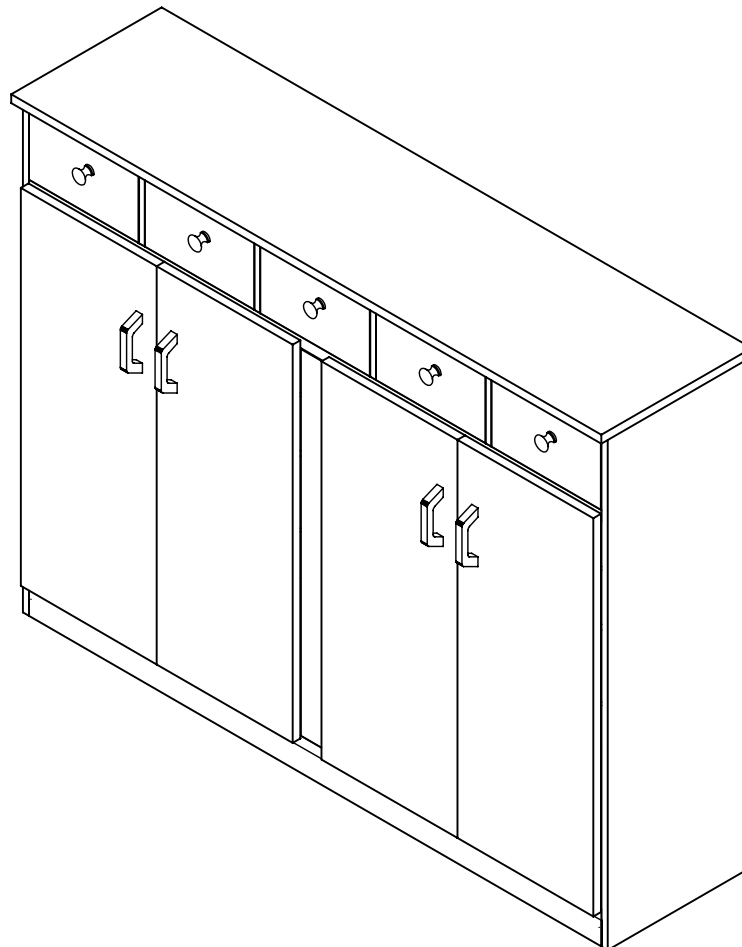













**OR SEND US EMAIL AT**

**[help@spartakent.com](mailto:help@spartakent.com)**

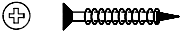
PLEASE HAVE ITEM NUMBER READY, AND A REPRESENTATIVE WILL GLADLY ASSIST YOU

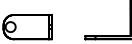

# HARDWARE LIST

HARDWARE	PART#	DESCRIPTION	QTY
	MAGDBBL	DOUBLE MAGNET	2
	SP816BL	PAN HEAD SCREW	4
	STPLTBL	MAGNETIC PLATE	4
	SF612A	FLAT HEAD SCREW	4
	HIN50SW	HINGE	8
	GLUEWD	WOOD GLUE	2
	HNDLWDBL	HANDLE	4
	SRM825B	MACHINE SCREW	13
	SHBRBL	SHELF BRACKET	24
	CAMLT12	CAMLOCK	19
	CAMBT12	BOLT	19
	DOWW525	WOOD DOWEL	38
	NAIL1734	NAIL	36
	SP811BL	TRUSS HEAD SCREW	72
	SFH825A	WOOD SCREW	8
	SFH845A	WOOD SCREW	10
	BPBL5	SHELF SUPPORT	8
	SHRTBL238	SHELF RETAINER CLIP	12
		SUPER GLUE GEL	1
	KN30	KNOB	5
	BM25	BRACKET ANGLE	2
	SPE610BL	EURO SCREW	4

# HINGE & SHELF ADJUSTMENT

If you find your doors out of alignment, if gap between doors is uneven, too big, or too small use this diagram to adjust your doors.

## UP-DOWN ADJUSTMENT

Loosen screws. Hinge can now slide up or down as required tighten screws after adjustment is made. Make sure do not overtighten the screws as you may strip the wood. It will be a good idea not to use power drill.

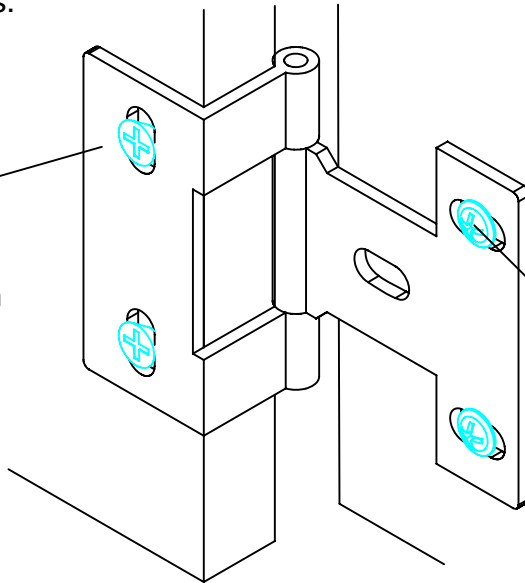

## SIDE TO SIDE ADJUSTMENT

Loosen screws. Hinge can now slide side to side as required tighten screws after adjustment is made.

Make sure do not overtighten the screws as you may strip the wood. It will be a good idea not to use power drill.

To prevent disk cases or tapes from falling over on the pocket door shelves don't leave open space for to them move around. Fill shelves up or use end blocks.

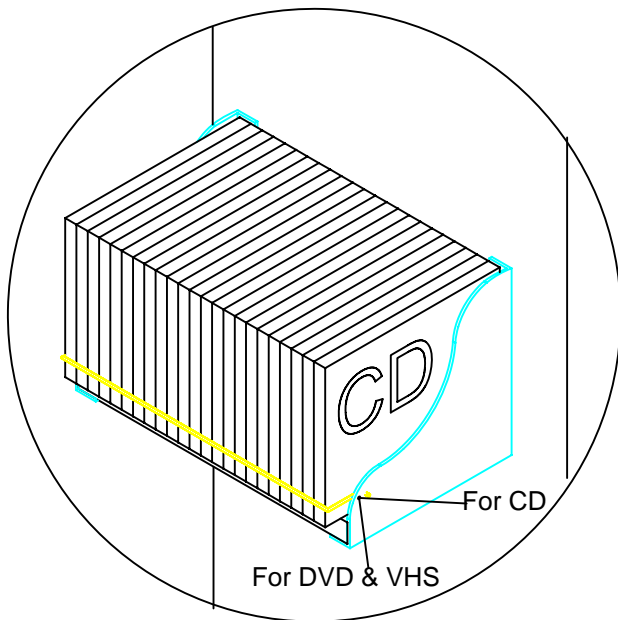

**YES**

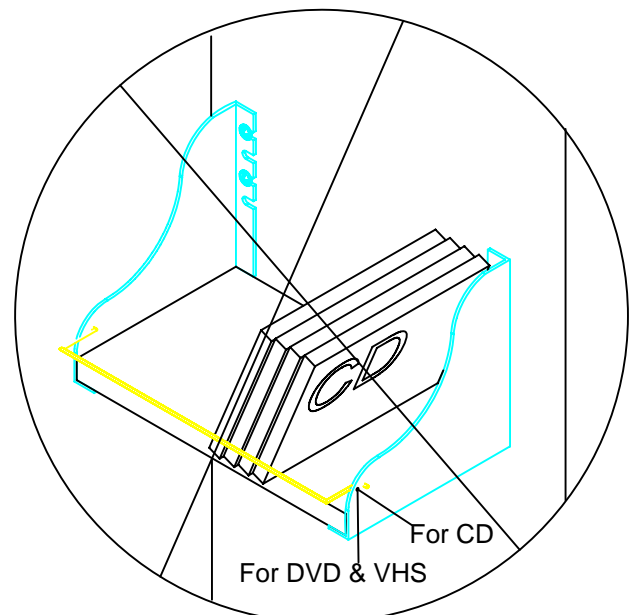

**NO**

# PARTS IDENTIFICATION

NOTE: FIRST MAKE SURE THAT YOU HAVE ALL OF THE PARTS LISTED ON THIS SHEET. IF YOU ARE MISSING ANY PIECE(S), DO NOT ASSEMBLE THE UNIT. INSTEAD, CALL OUR CUSTOMER SERVICE NUMBER AT: (888) 777-8250. WE WILL BE HAPPY TO ASSIST YOU.

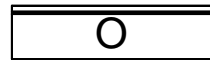
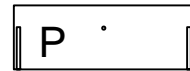
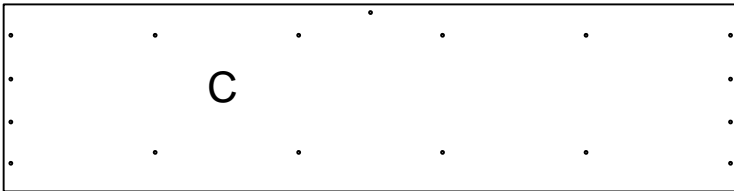
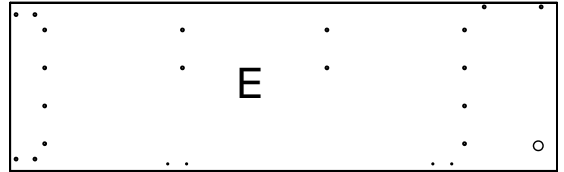
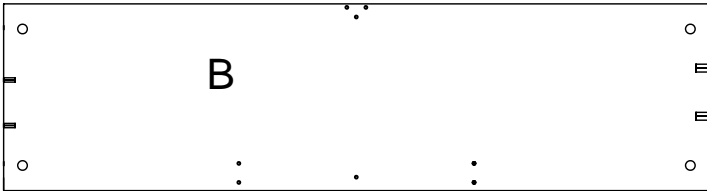
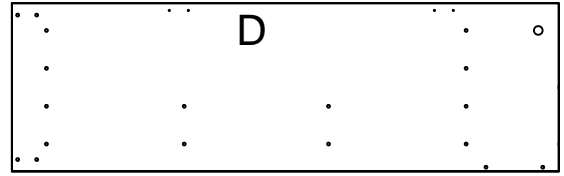

M

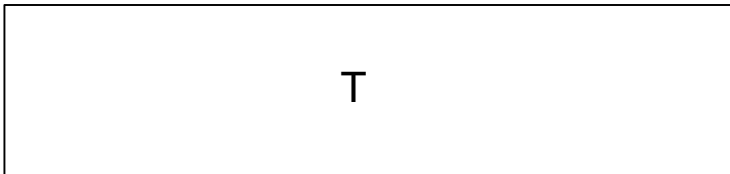
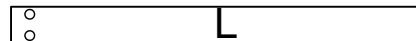
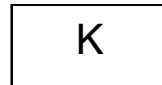
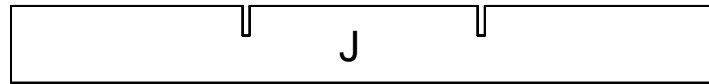
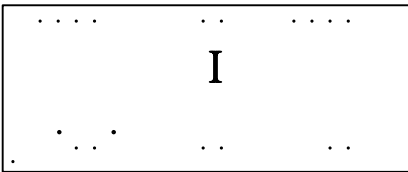
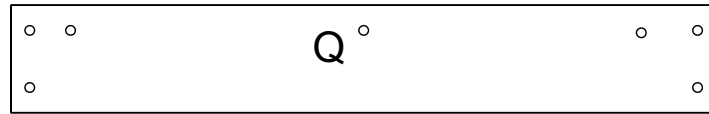
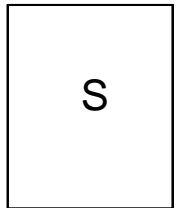
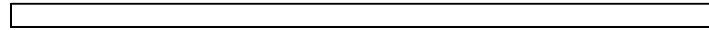
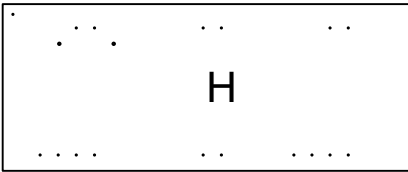

- 2362I-Left Door 2pcs
- 2368J-Shelf 2pcs
- 2368K-Divider 4pcs
- 2362L-Face Frame 1pc
- 2362M-Brace 2pcs
- 2368N-Dr. Left Side 5pcs
- 2368O-Dr. Right Side 5pcs
- 2368P-Drawer Front 5pcs
- 2368Q-Back Rail 1pc
- 2368R-Drawer Back 5pcs
- 2368S-Drawer Bottom 5pcs
- 2362T-Back Panel 3pcs

- 2368A-Fixed Shelf 1pc
- 2368B-Bottom 1pc
- 2368C-Top 1pc
- 2368D-Left Side 1pc
- 2368E-Right Side 1pc
- 2360F-Door Shelf 12pcs
- 2368G-Divider 2pcs
- 2362H-Right Door 2pcs

**PARTS ARE USUALLY MARKED ON THE RAW EDGE.**

1

PUSH wood dowels in as far as they can go. They shouldn't stick out more than 3/8"

UNLOCKED POSITION

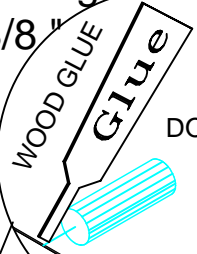

DOWW525

CAMBT12

UNLOCKED POSITION

UNLOCKED POSITION

D & E

L

Q

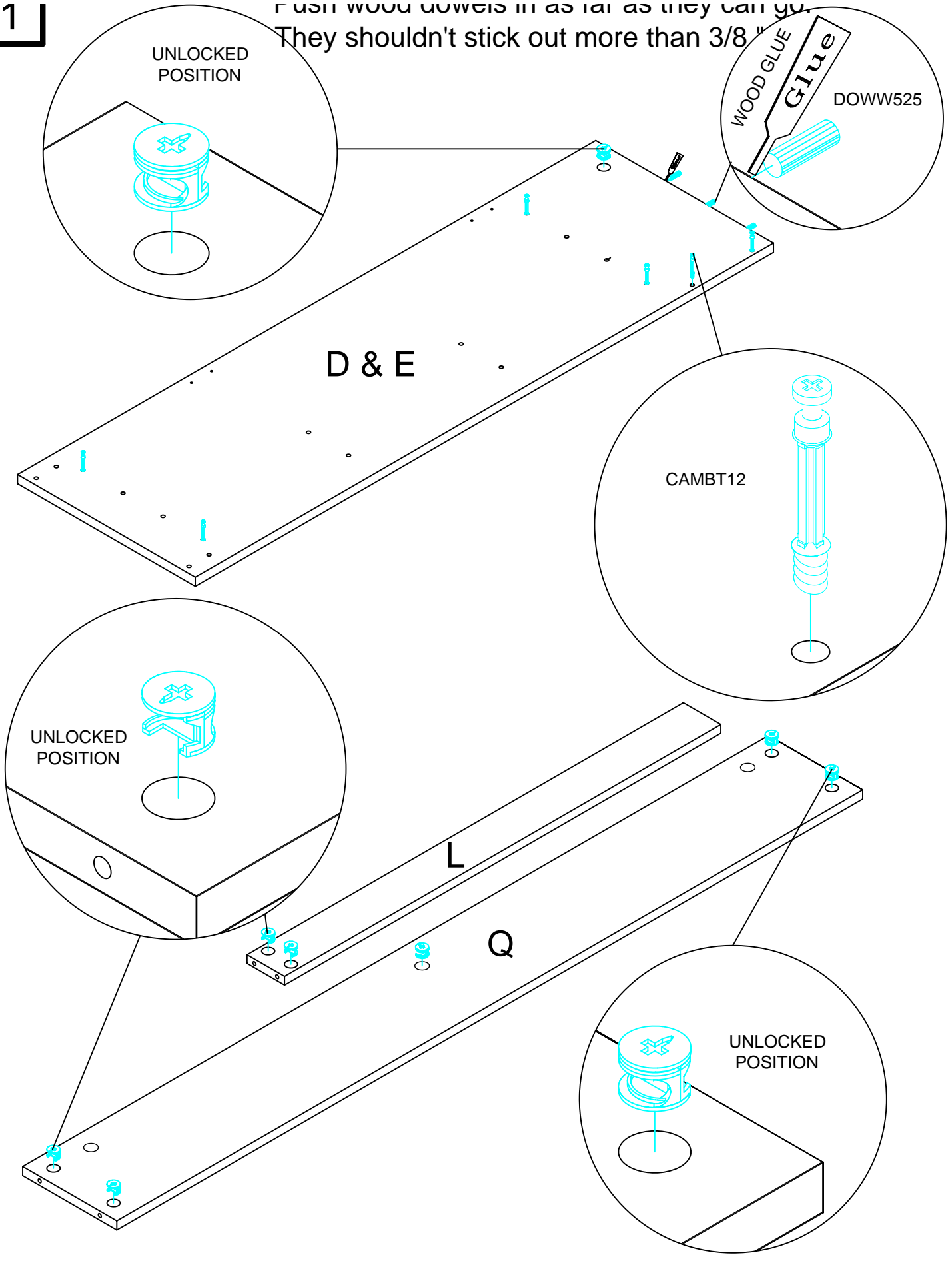

2

Push wood dowels in as far as they can go.  
They shouldn't stick out more than 3/8"

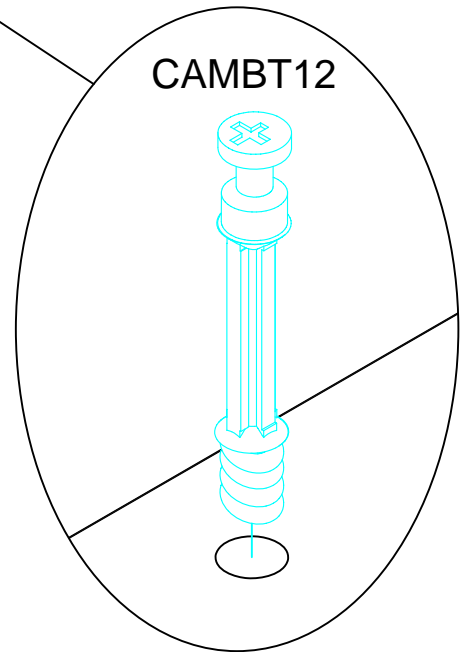
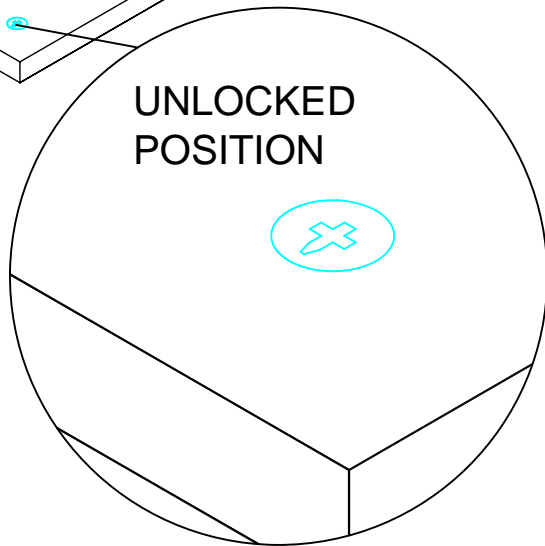
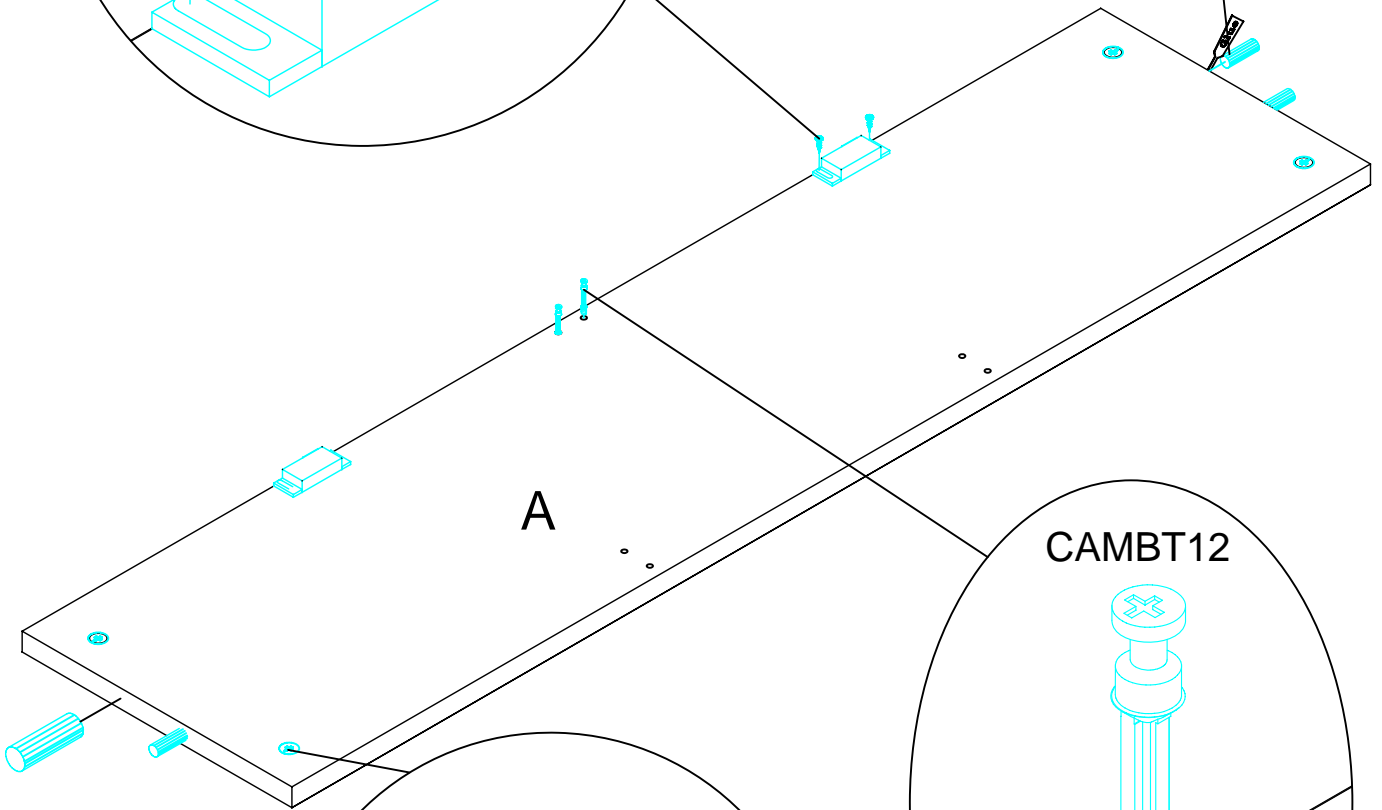
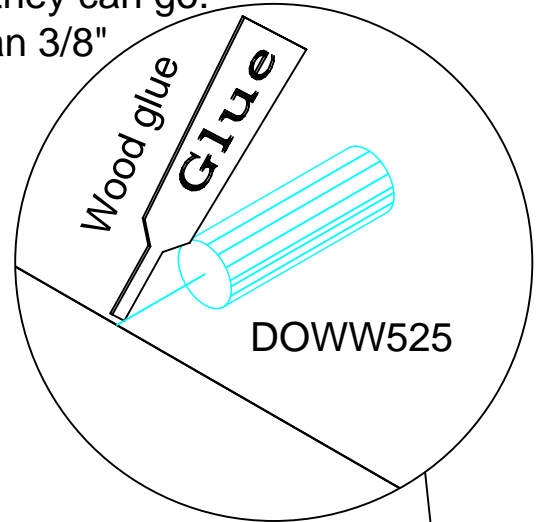
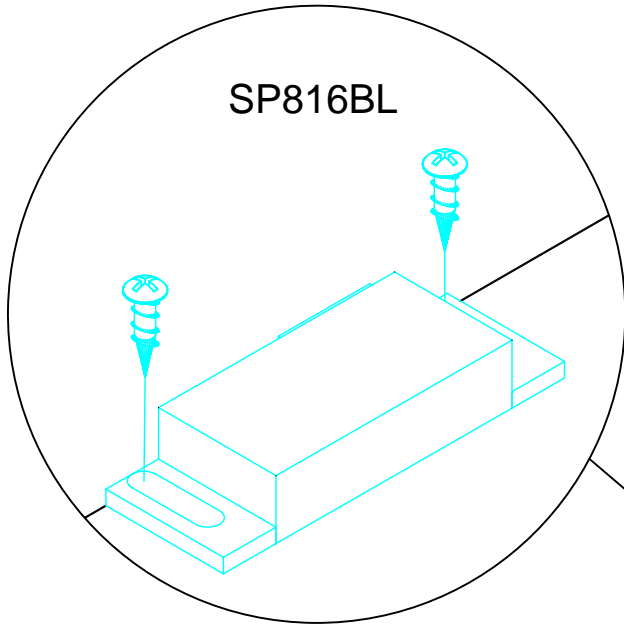

3

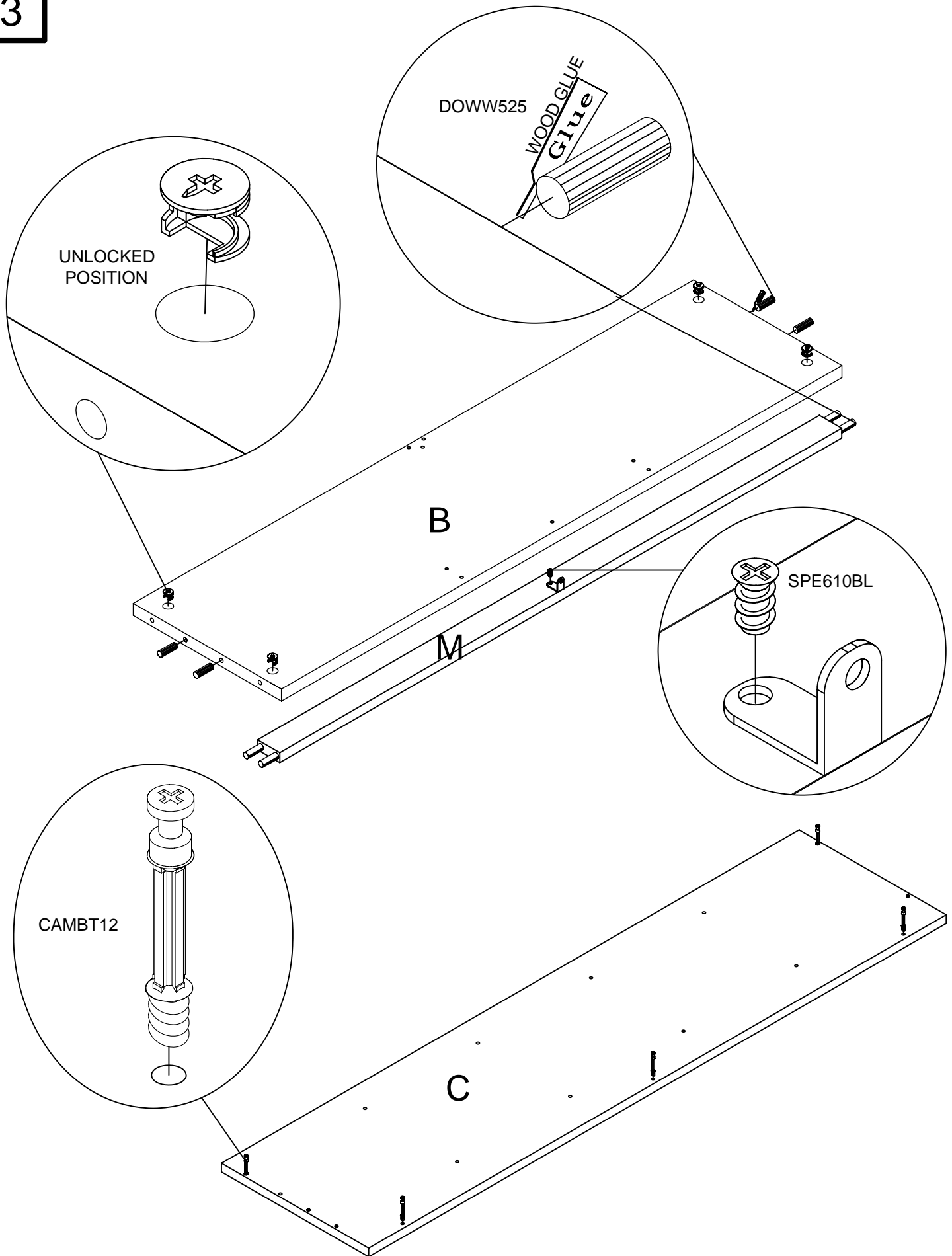

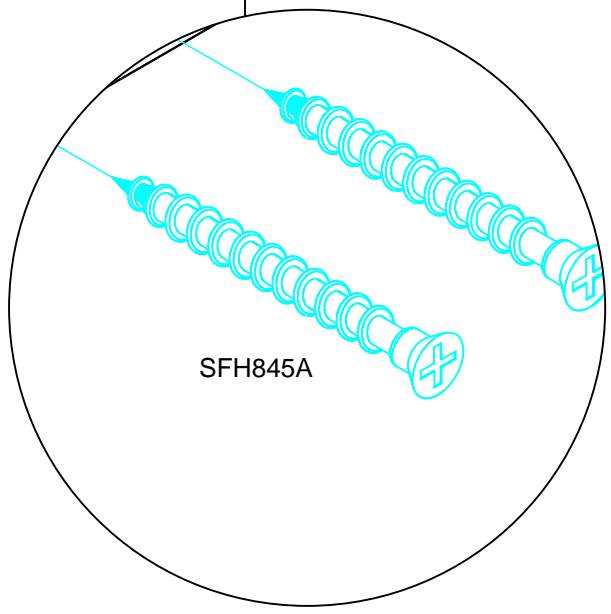
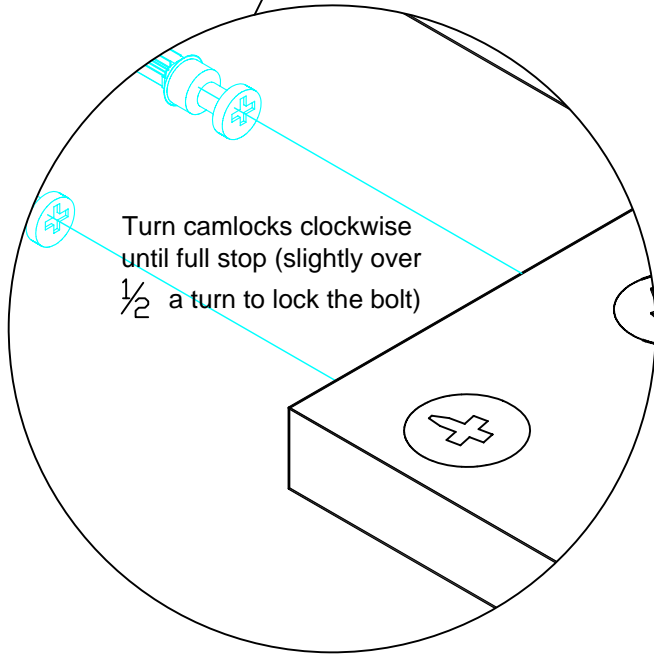
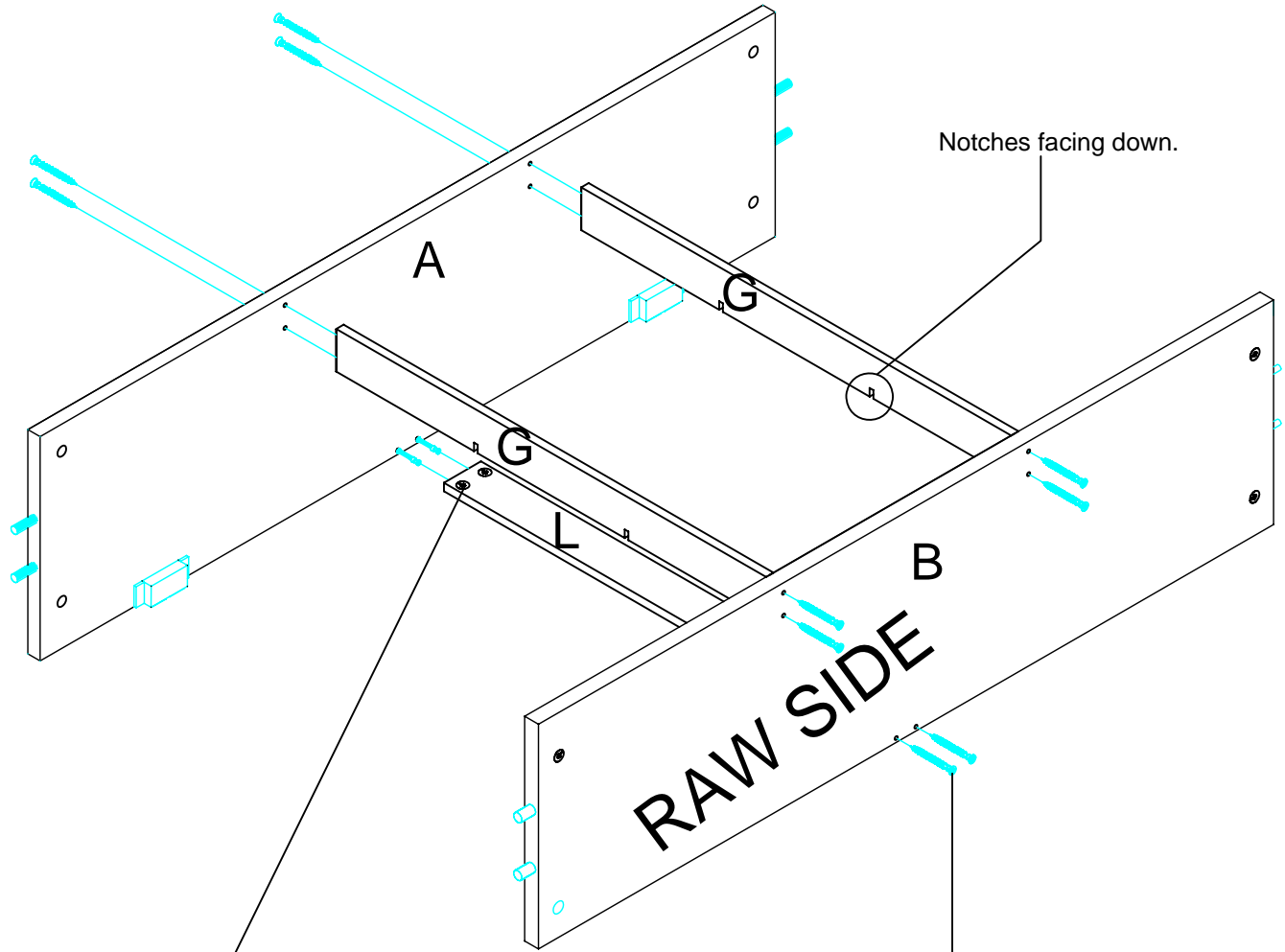

Raw edges of all parts facing back.

Laminated side of part m facing forward.

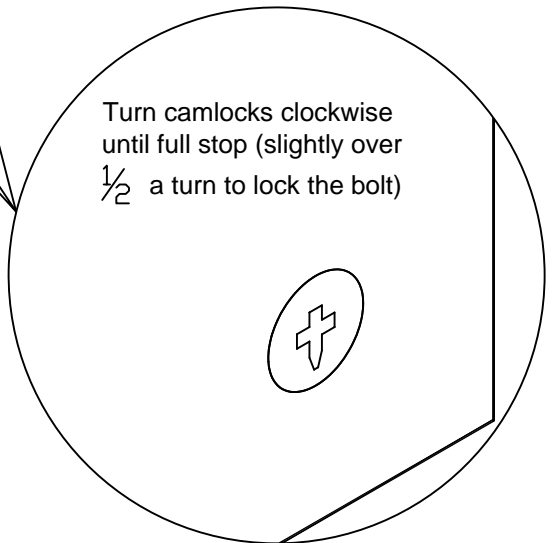
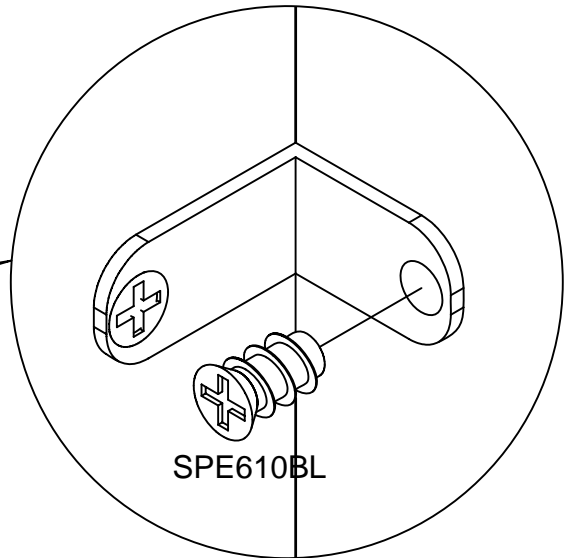
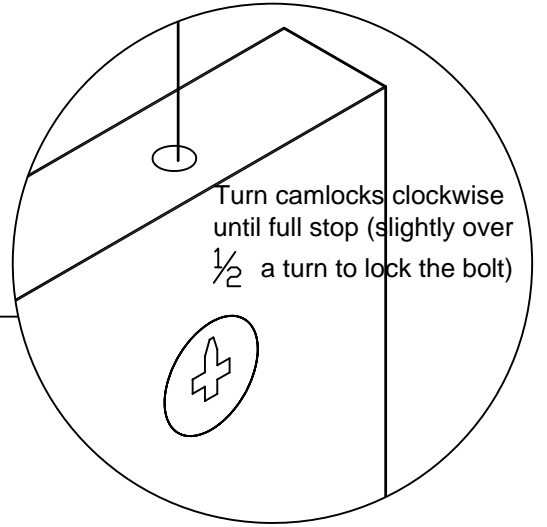
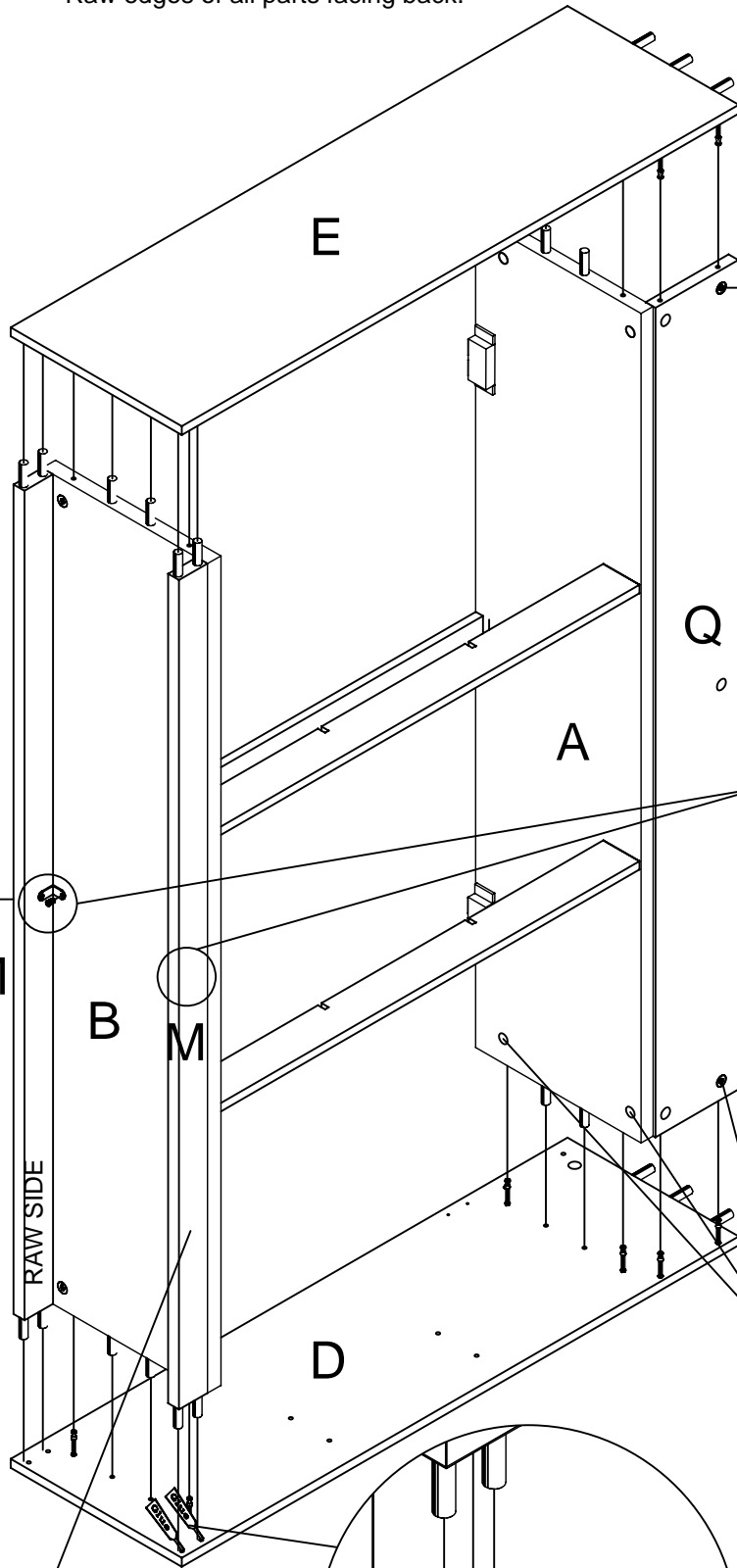

This part M comes unfinished.

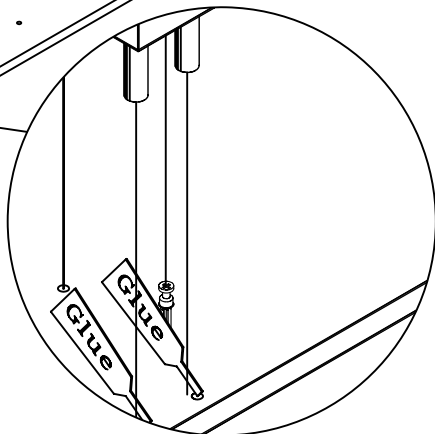

6

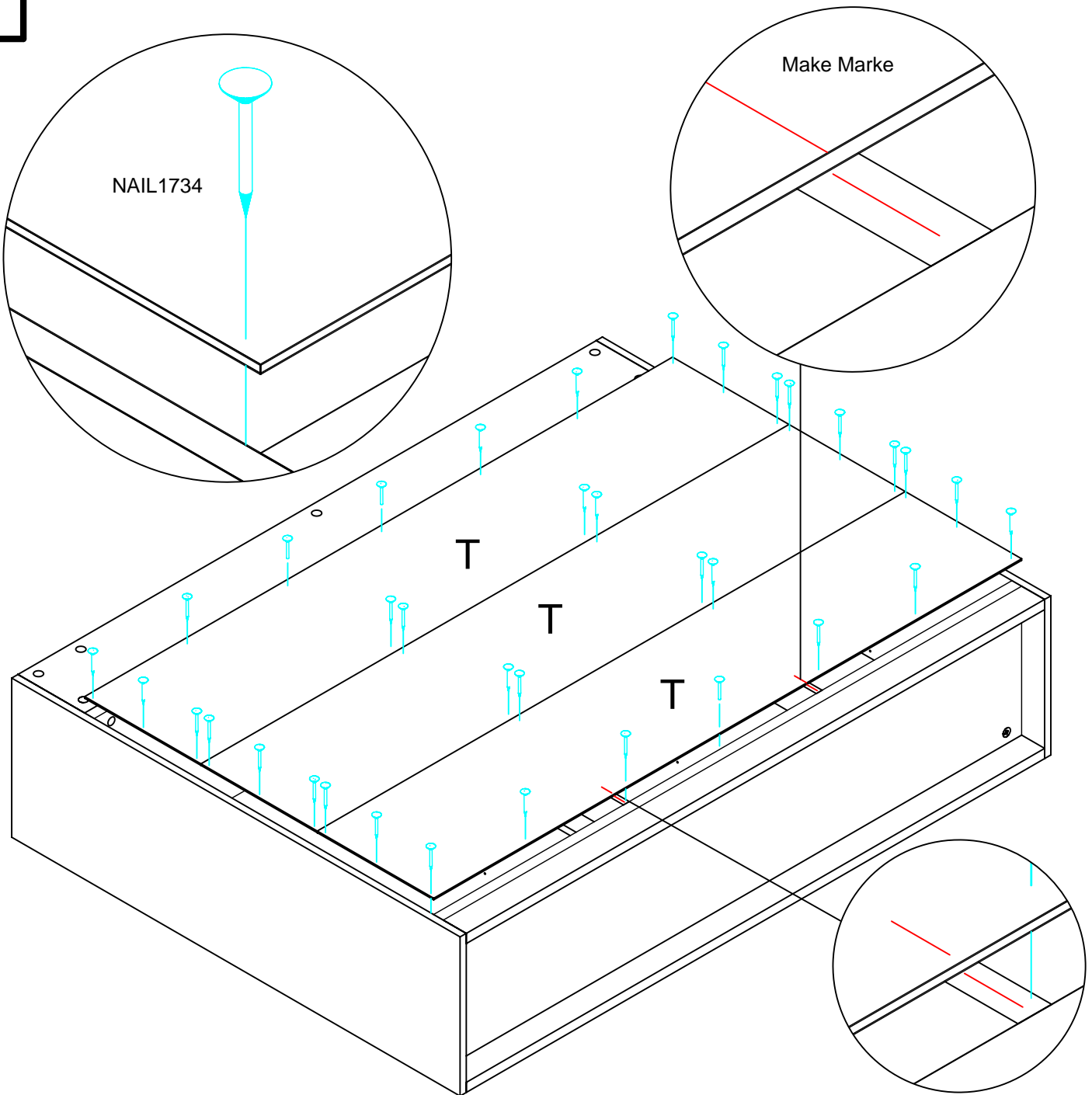

Place the unit face down. Before attempting to nail back panels (T) to the assembly, make marks with pencil or marker pen on the raw edges of panels (A) & (B) corresponding to the location of center of the edges of dividers (G). Align the back panels (T) over the unit. Make sure the assembly is square and leave equal amount of margin all around. Tack the two opposing corners of the back panel down, first using nails as shown, then the other two. Next, nail the pack panel all around with approximately 6" spacing between the nails. Make sure to keep the nails centered on the edges to avoid splitting of the boards. To complete installing the back panels (T), you will need to draw a straight line connecting the marks you made earlier on the edges of (A) and (B) panels across back panels (T). Make sure to draw the lines in between the marks made. The lines will be your guide for nailing panels (T) to dividers (G) underneath

7

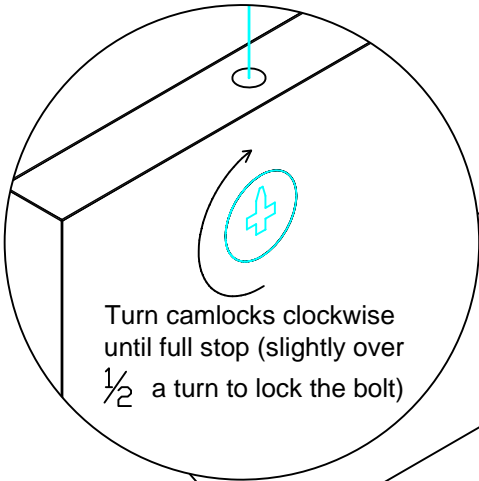

Turn camlocks clockwise until full stop (slightly over  $\frac{1}{2}$  a turn to lock the bolt)

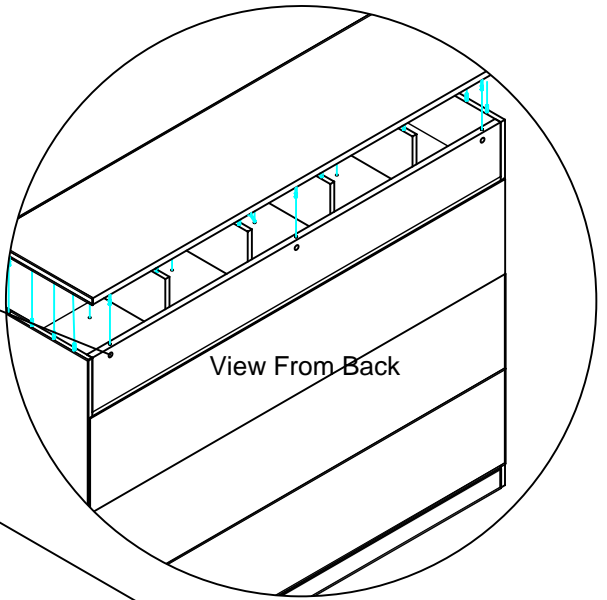

View From Back

Laminated Edge

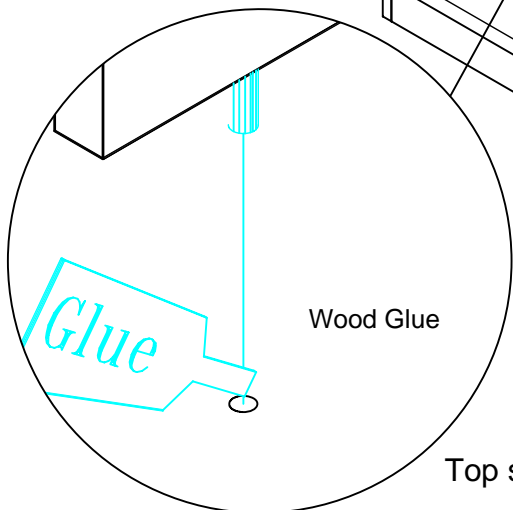
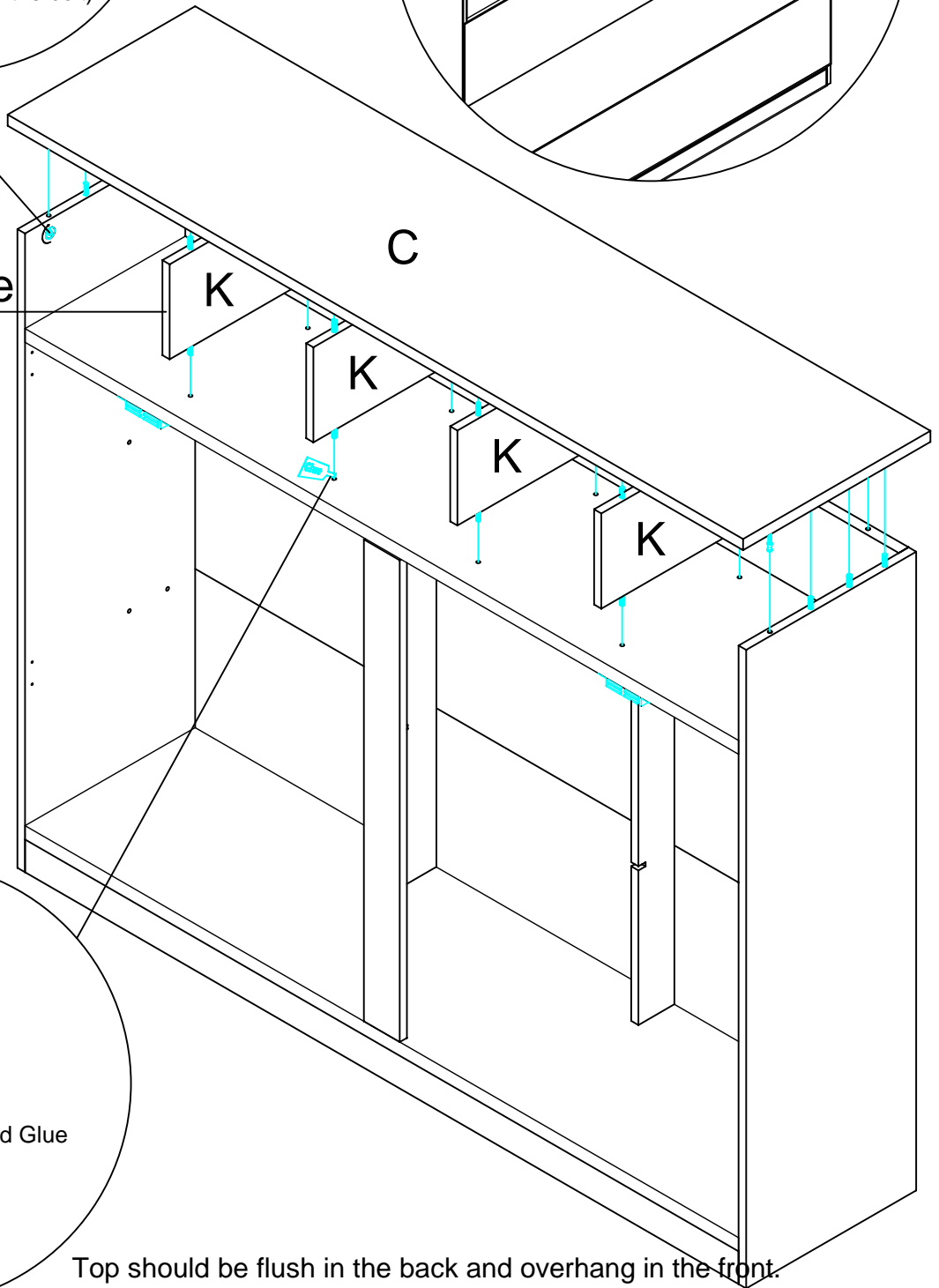

Wood Glue

Top should be flush in the back and overhang in the front.

Push down on the top and place some weight on it (few books) and don't lift unit by the top until glue has set.

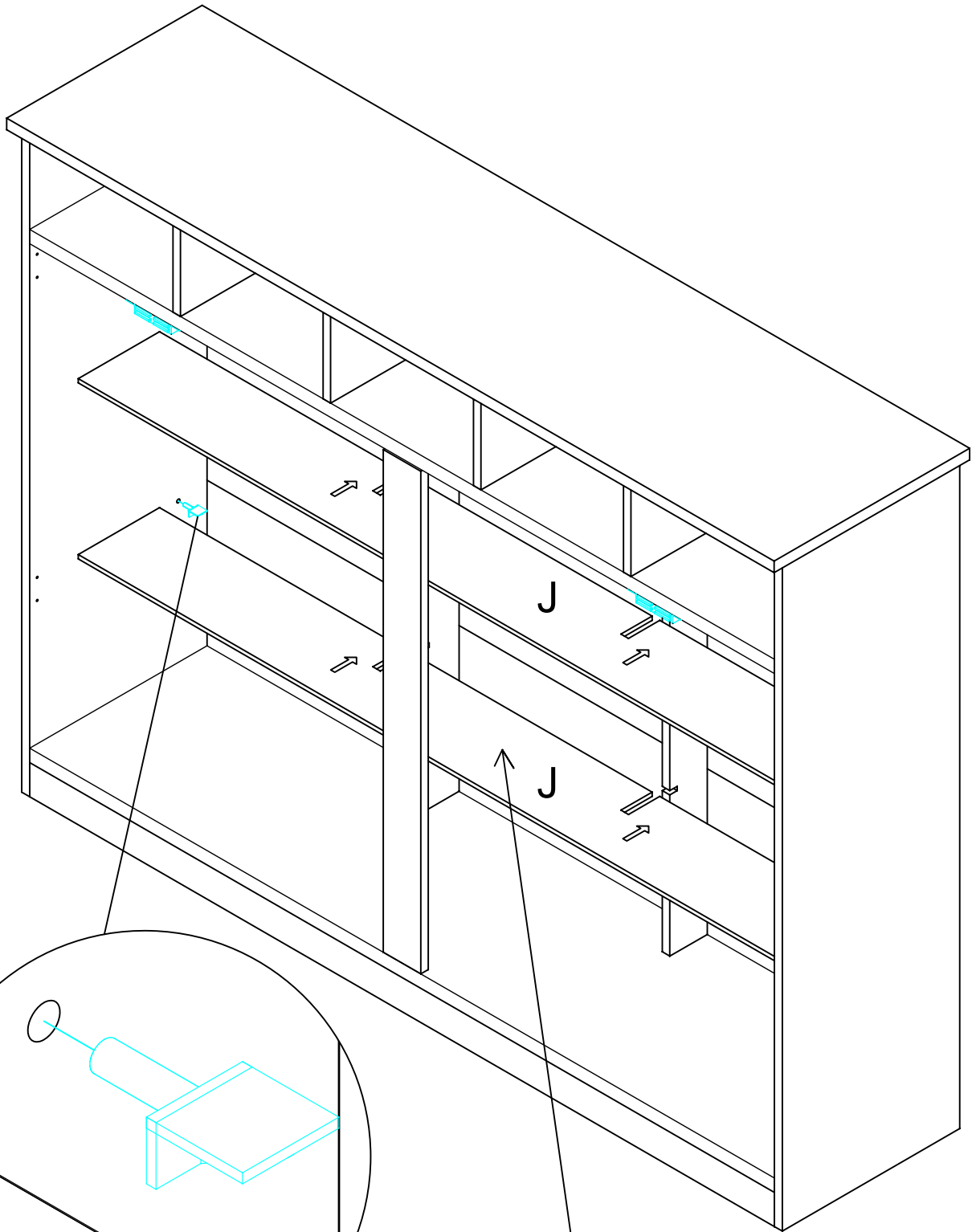

Black side up

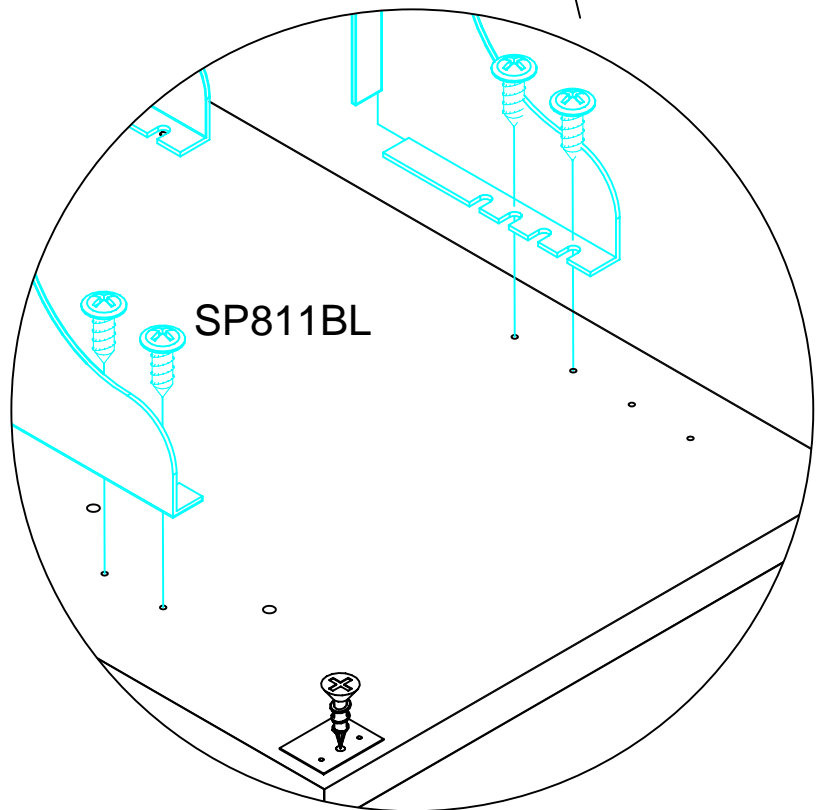
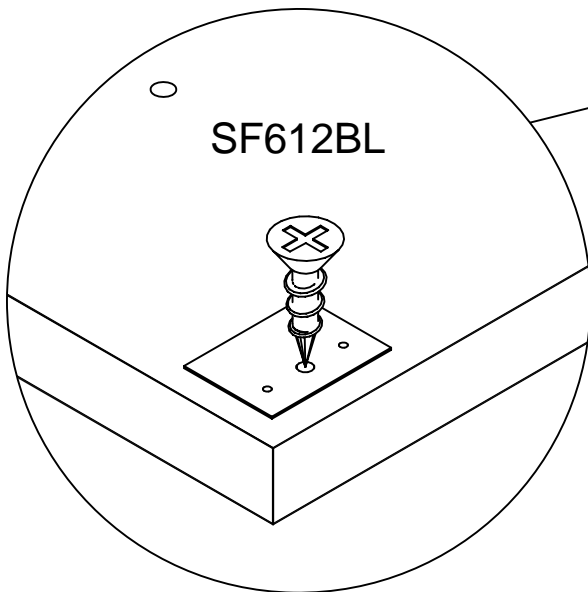
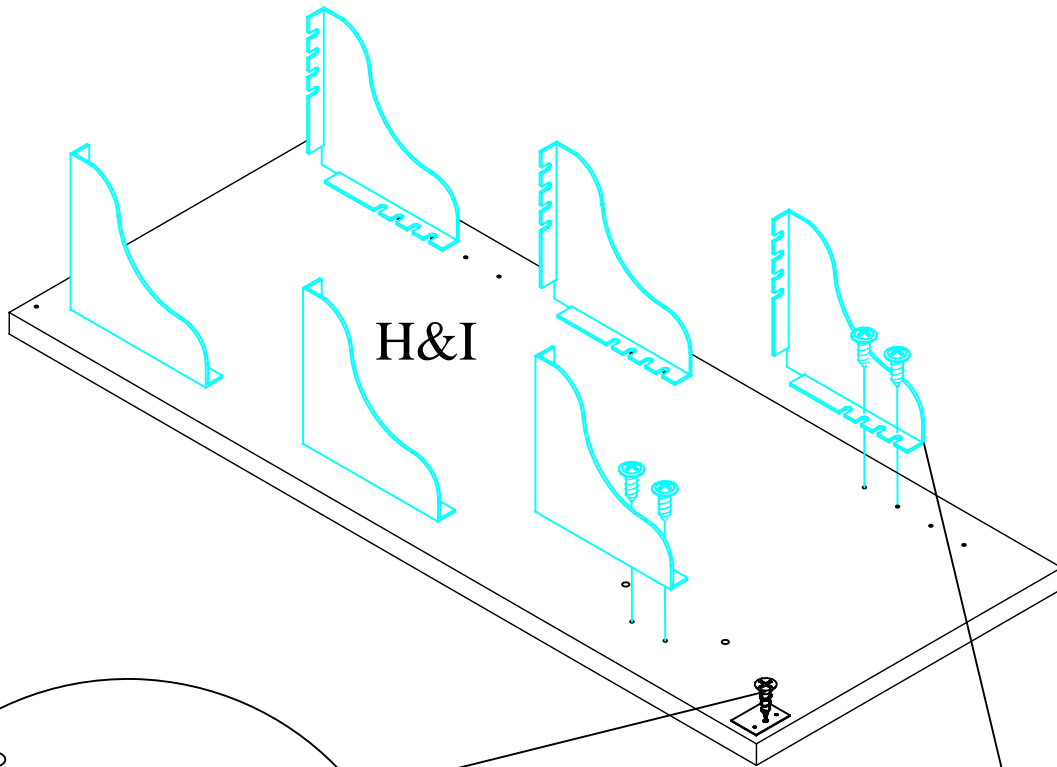

If you wish to use this unit for Disney cases you may move second shelf one hole up on the brackets and eliminate top shelf.

10

If you wish to use this unit for Disney cases you may move second shelf one hole up on the brackets and eliminate top shelf.

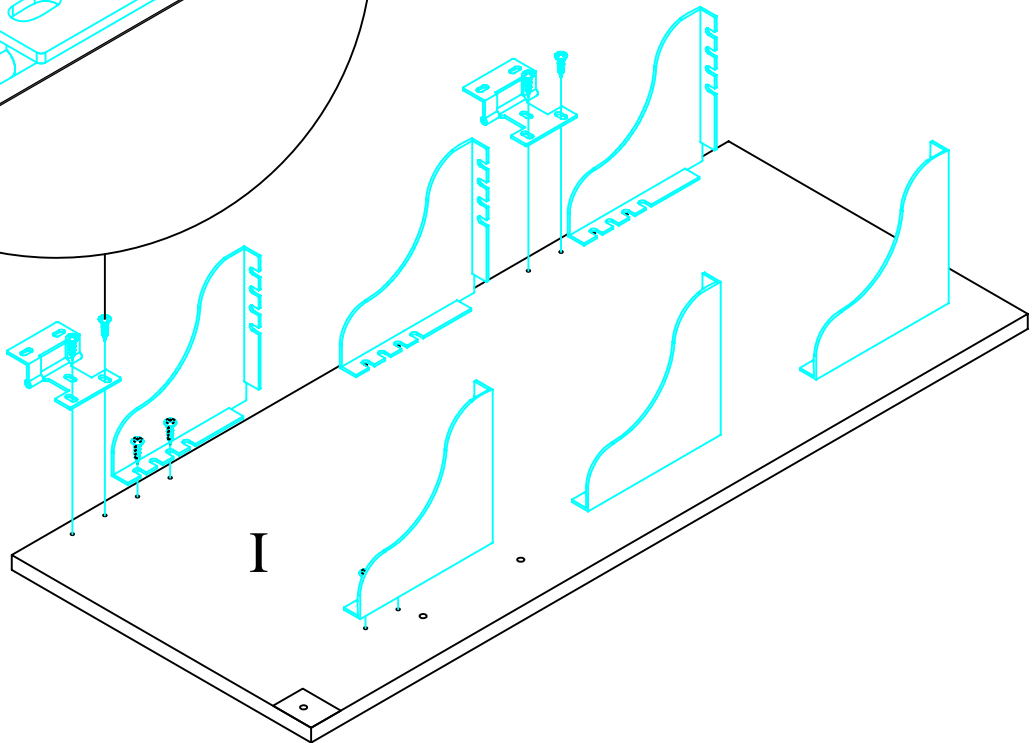
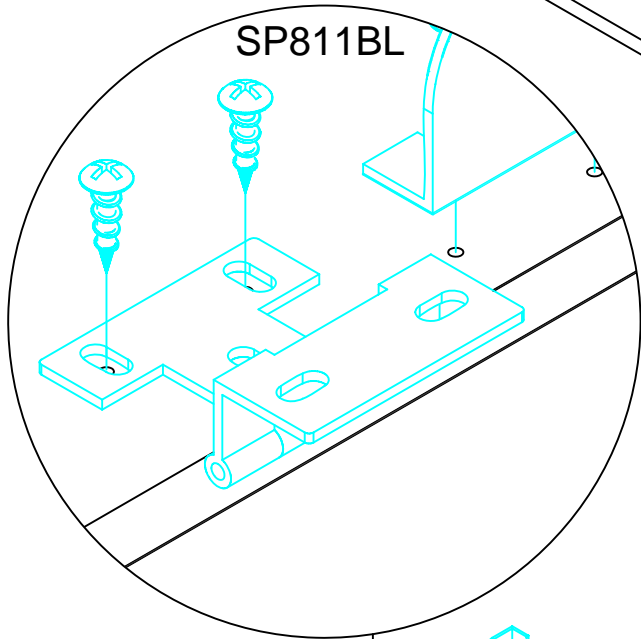
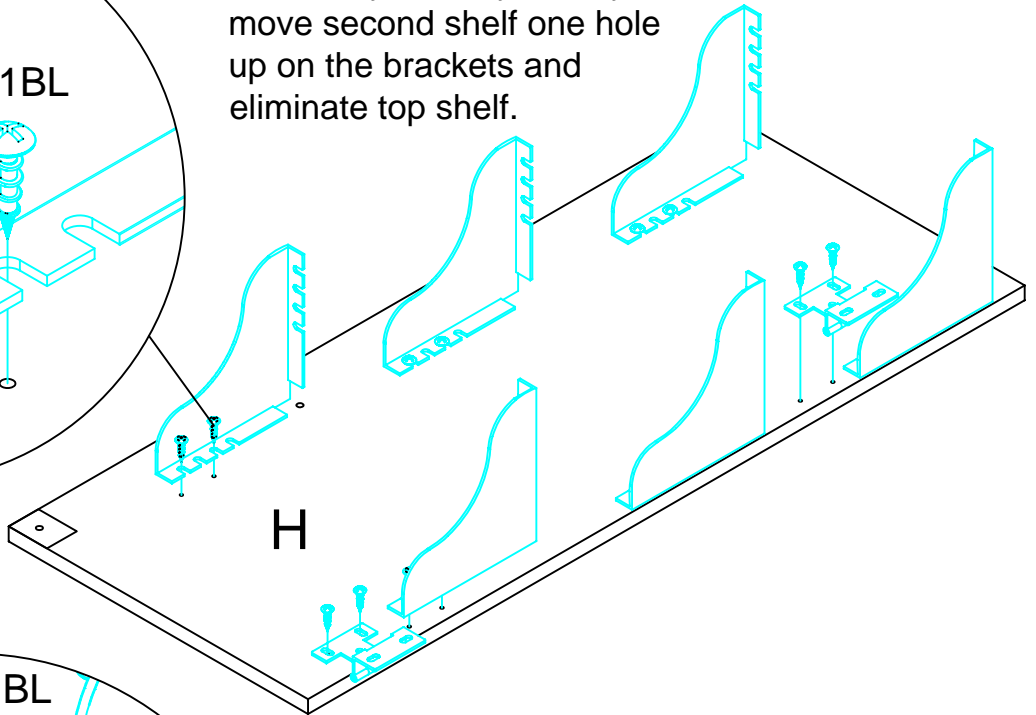
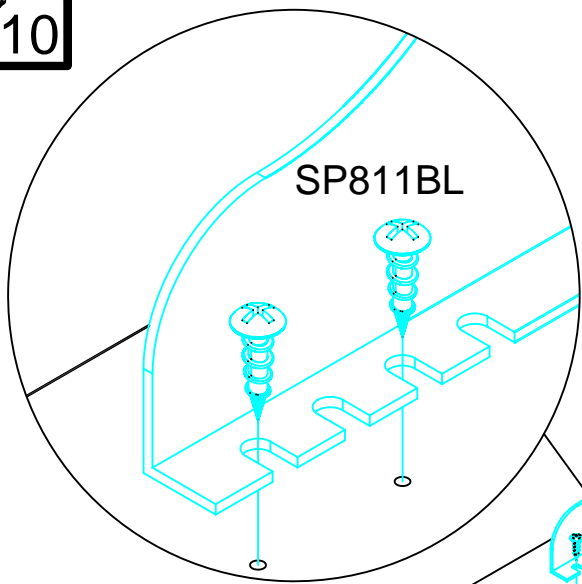

Make sure do not use longer screws (SFH825A) on outer panels, use them only on the middle doors.

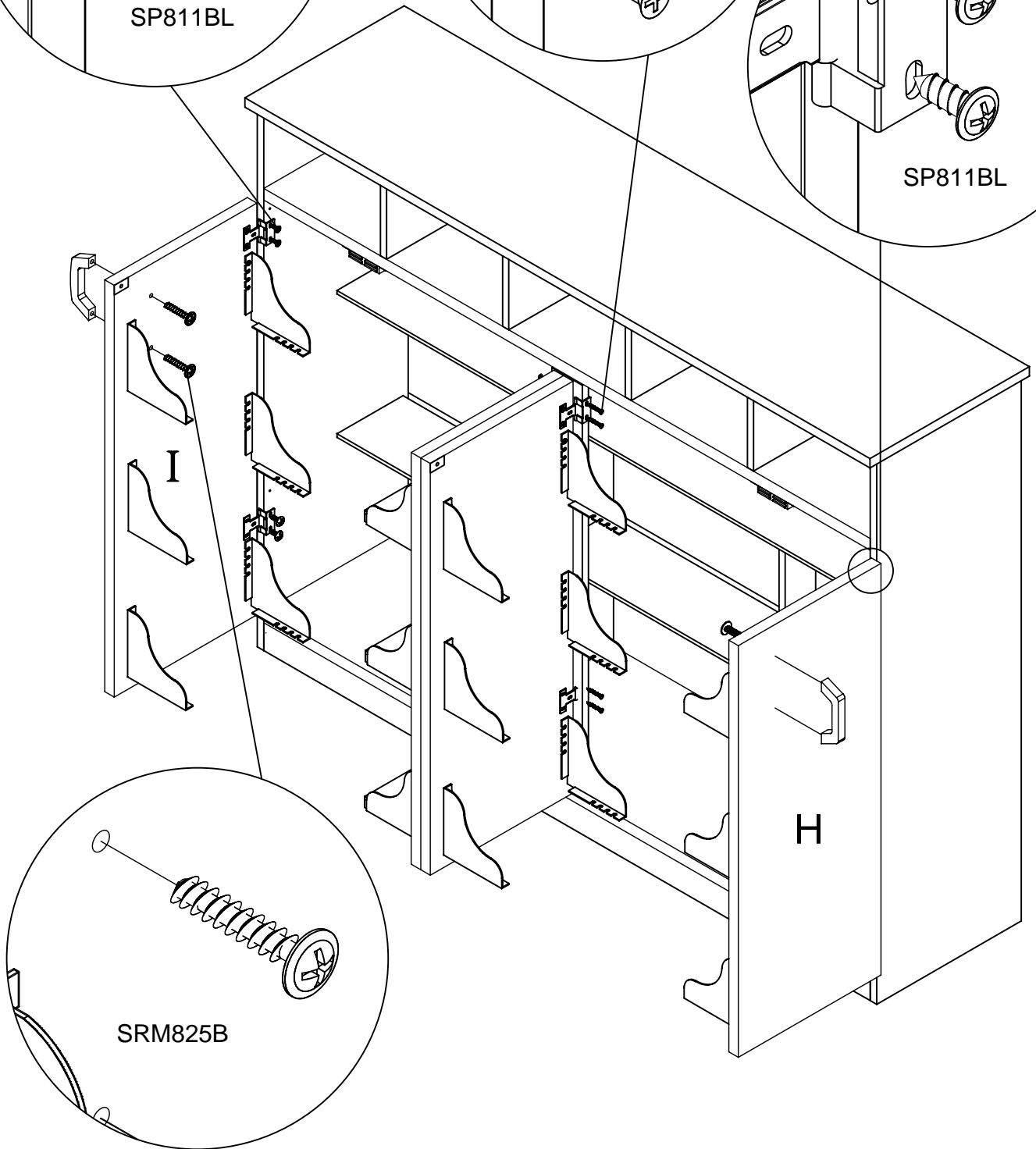
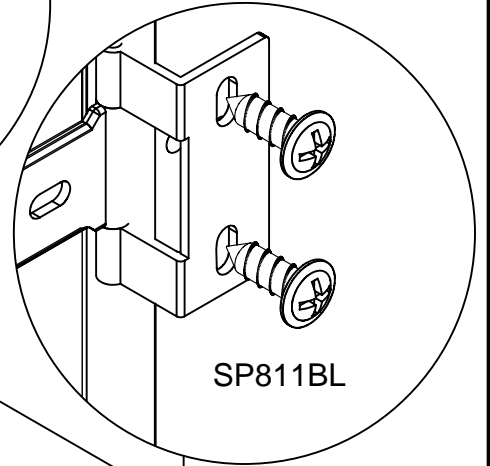
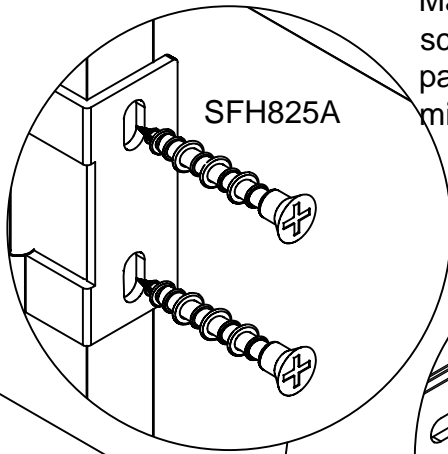
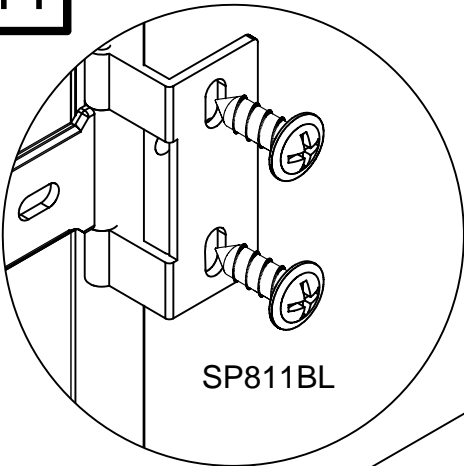

Apply thick coat of glue to drawer grooves on one of each parts (N), (O), and (R).

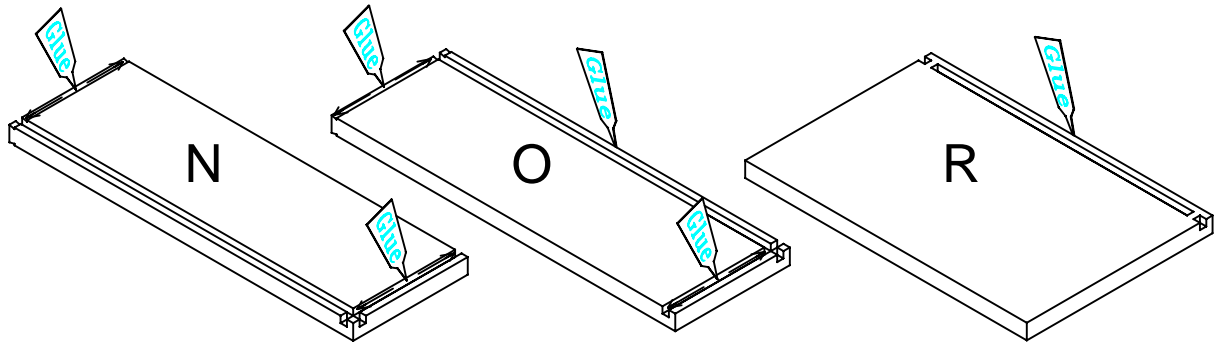

Assemble one drawer at the time to avoid glue setting in before you put parts together.

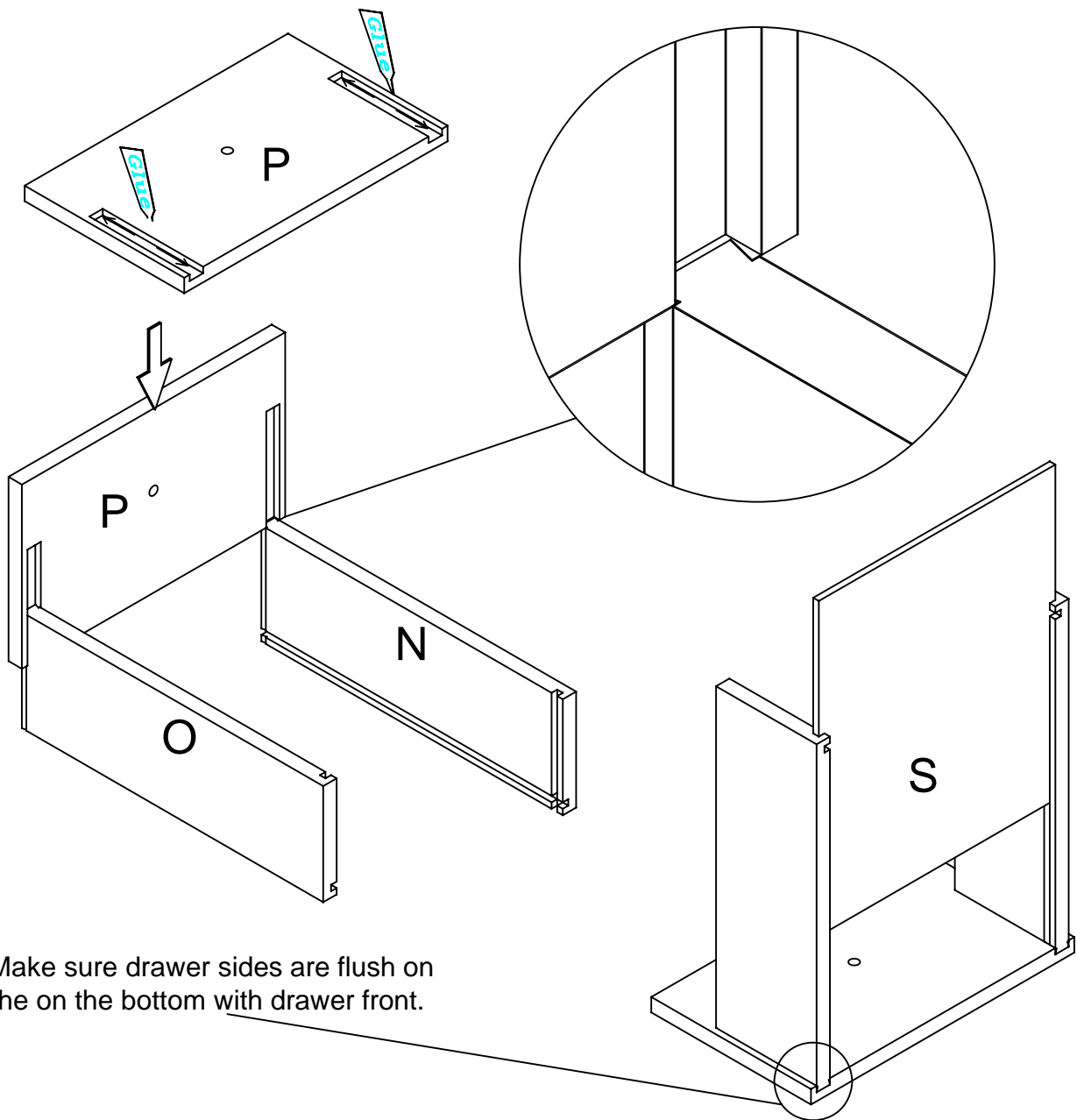

Make sure drawer sides are flush on the on the bottom with drawer front.

13

Insert (R) into drawer bottom (S). Repeat this process until all drawers are assembled. Allow at least two hours for glue to set.

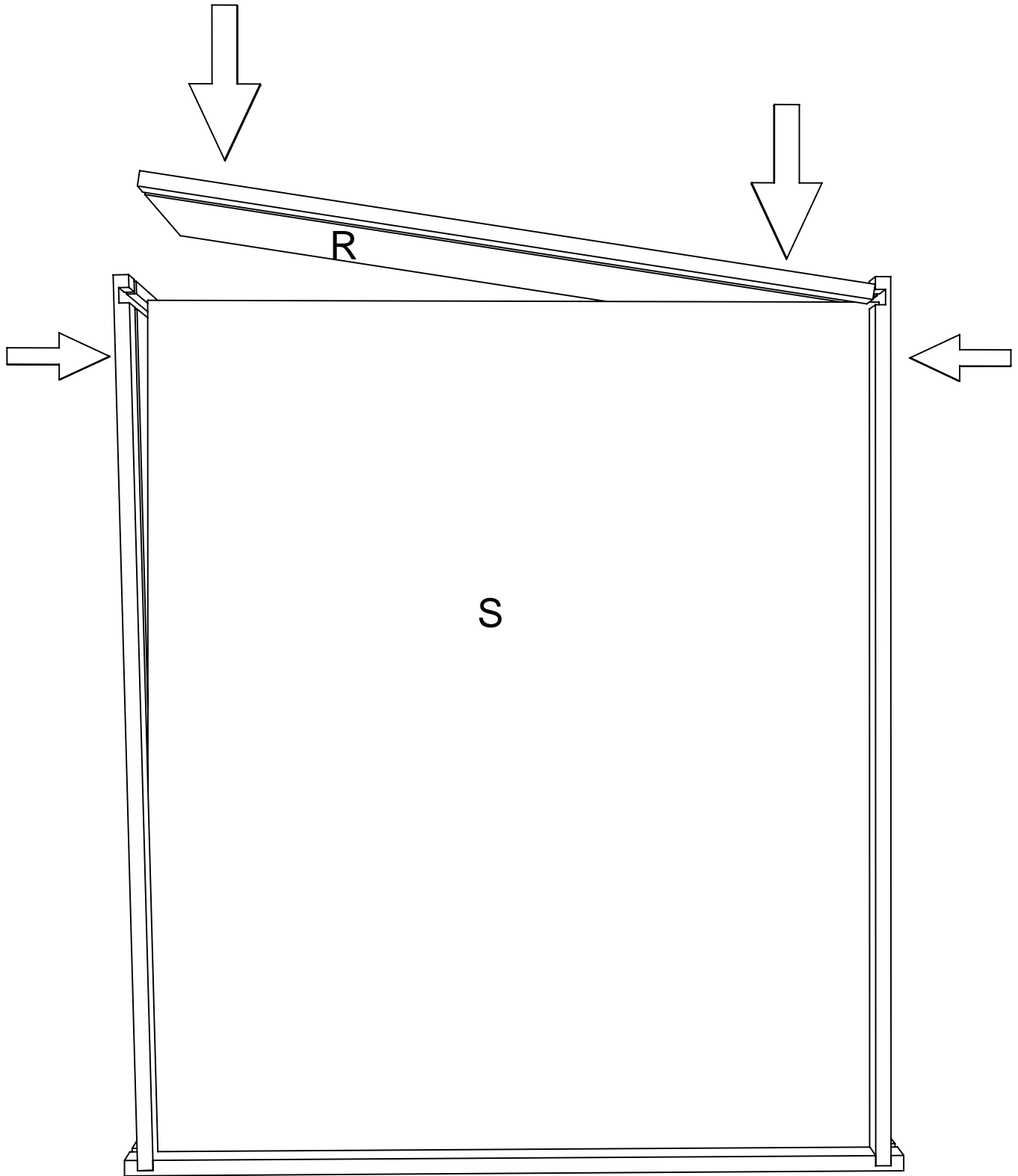

Excess glue around edges will turn translucent, once it has set.

14

Apply one drop of Super Glue Gel in two locations on each plastic shelf support bracket. Place shelf F on the brackets with finished side facing up and laminated edge facing out. Press down on the shelves and allow two hours for glue to set.

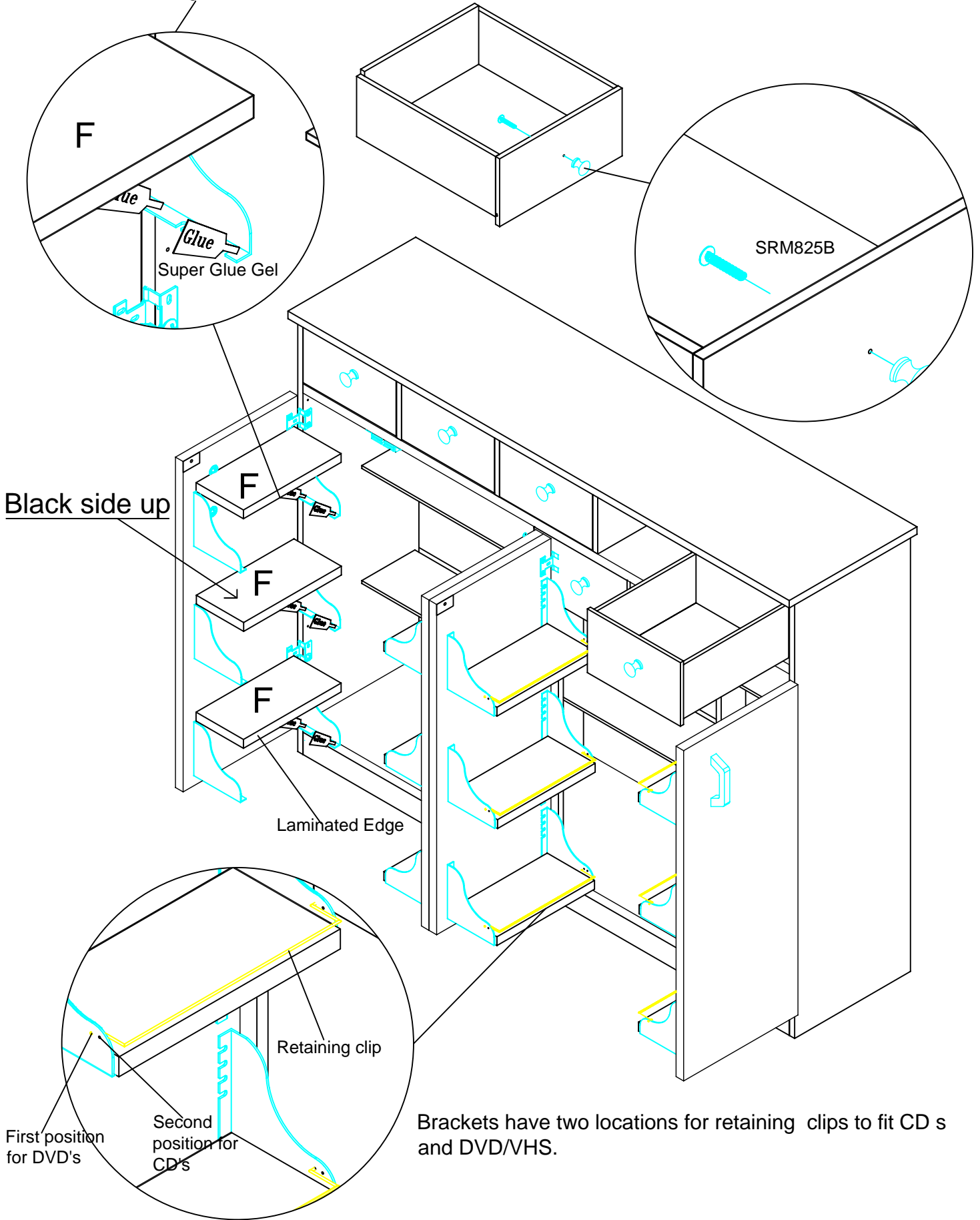

Brackets have two locations for retaining clips to fit CD s and DVD/VHS.