



IF PARTS ARE MISSING AND OR DEFECTIVE, IF INSTRUCTIONS ARE NOT CLEAR  
OR IF YOU ARE EXPERIENCING PROBLEMS ASSEMBLING OUR PRODUCT.

**BEFORE YOU RETURN THE PRODUCT TO THE STORE,  
PLEASE CALL US TOLL FREE FOR CUSTOMER SERVICE ASSISTANCE**

**(888) 777-8250**

**OR SEND US EMAIL AT**

**[help@spartakent.com](mailto:help@spartakent.com)**

PLEASE HAVE ITEM NUMBER READY, AND A REPRESENTATIVE WILL GLADLY ASSIST YOU

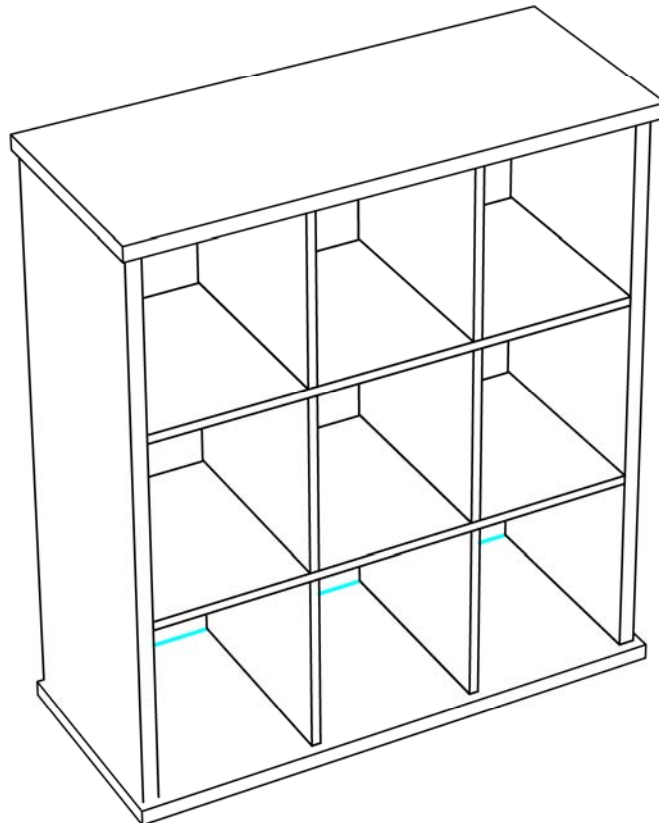

# PARTS IDENTIFICATION

NOTE: FIRST MAKE SURE THAT YOU HAVE ALL OF THE PARTS LISTED ON THIS SHEET. IF YOU ARE MISSING ANY PIECE(S), DO NOT ASSEMBLE THE UNIT. INSTEAD, CALL OUR CUSTOMER SERVICE NUMBER AT: (888) 777-8250. WE WILL BE HAPPY TO ASSIST YOU.

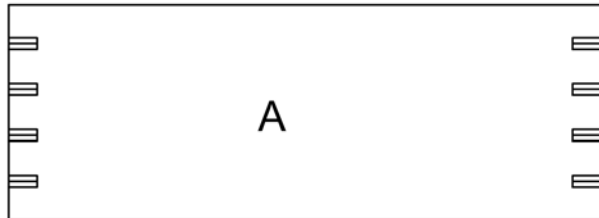

A

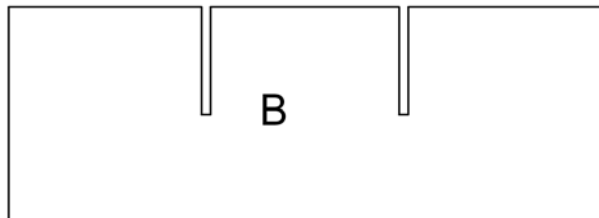

B

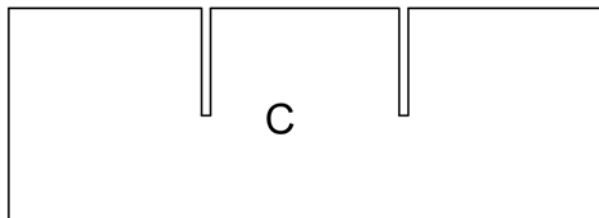

C

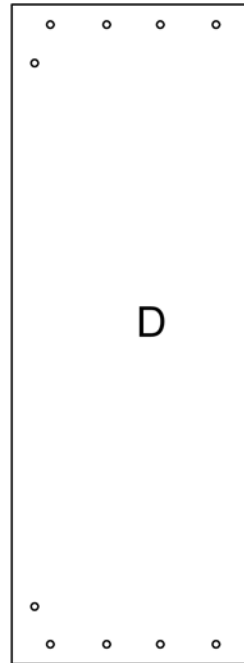

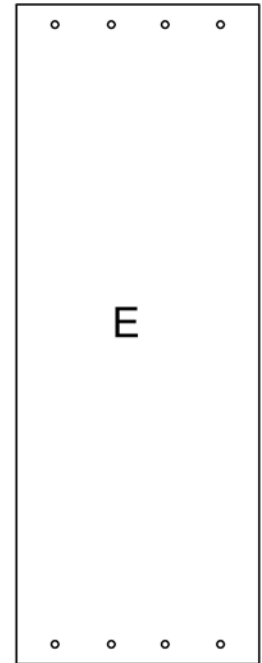

D



E

A-Side	2pcs
B-Divider	2pcs
C-Divider	2pcs
D-Top	1pc
E-Bottom	1pc

## HARDWARE LIST

HARDWARE	PART #	DESCRIPTION	QTY
	DOWW830	WOOD DOWEL	16
	GLUE	GLUE	1
	DOP2S16	PIN WITH WASHER	4

1

Tap dowels in with a hammer. Make sure the dowels go in as far as possible. They should stick out no more than 1/2 of an inch. Do not use more than one drop of glue as it may cause board to split.

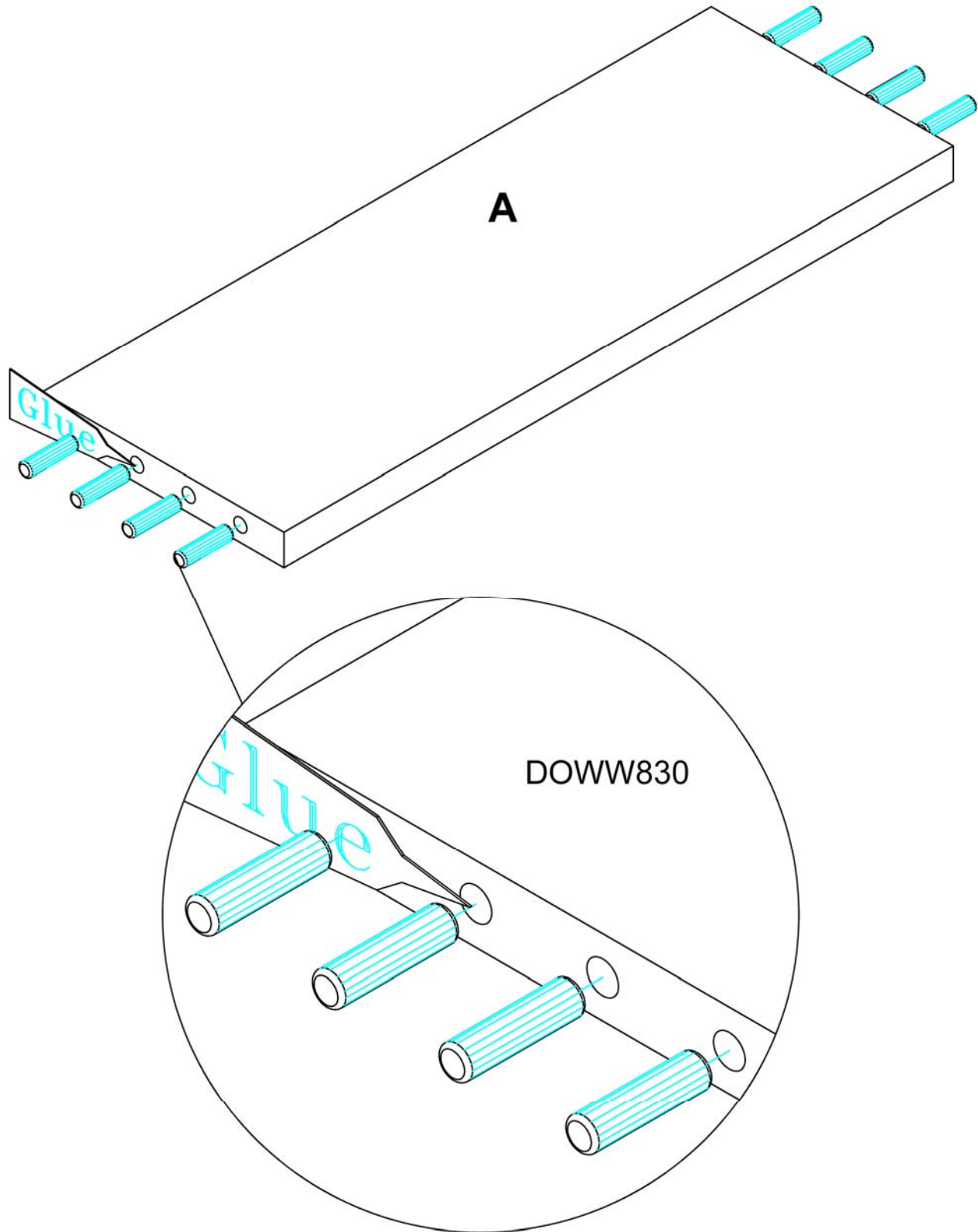

2

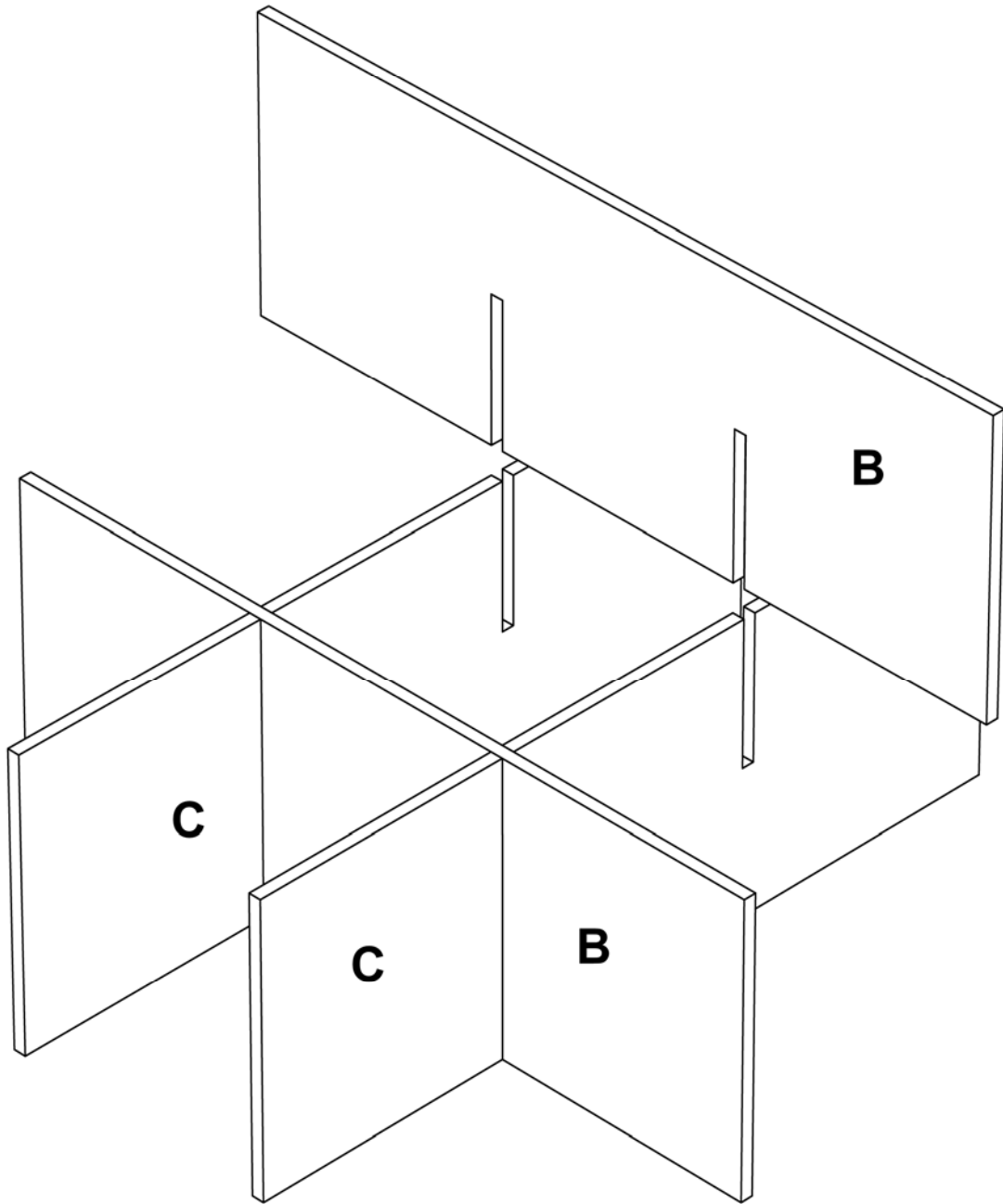

3

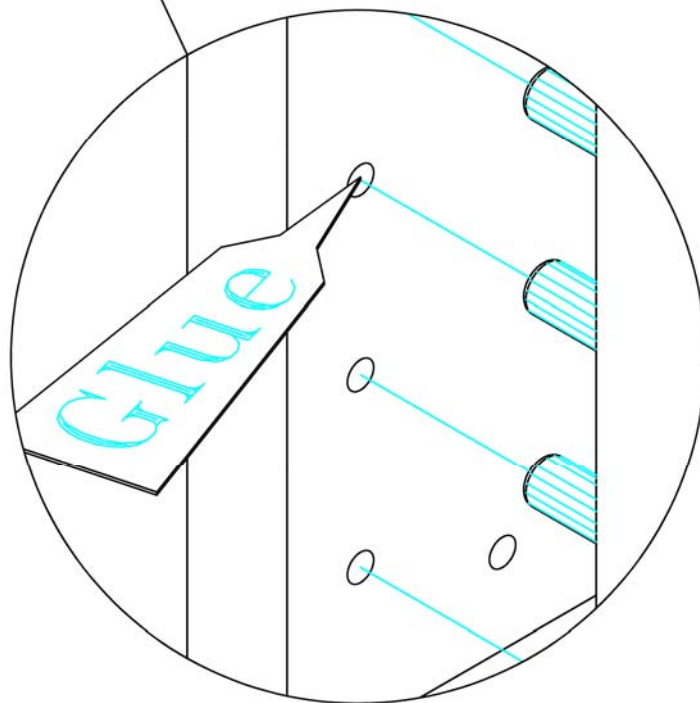
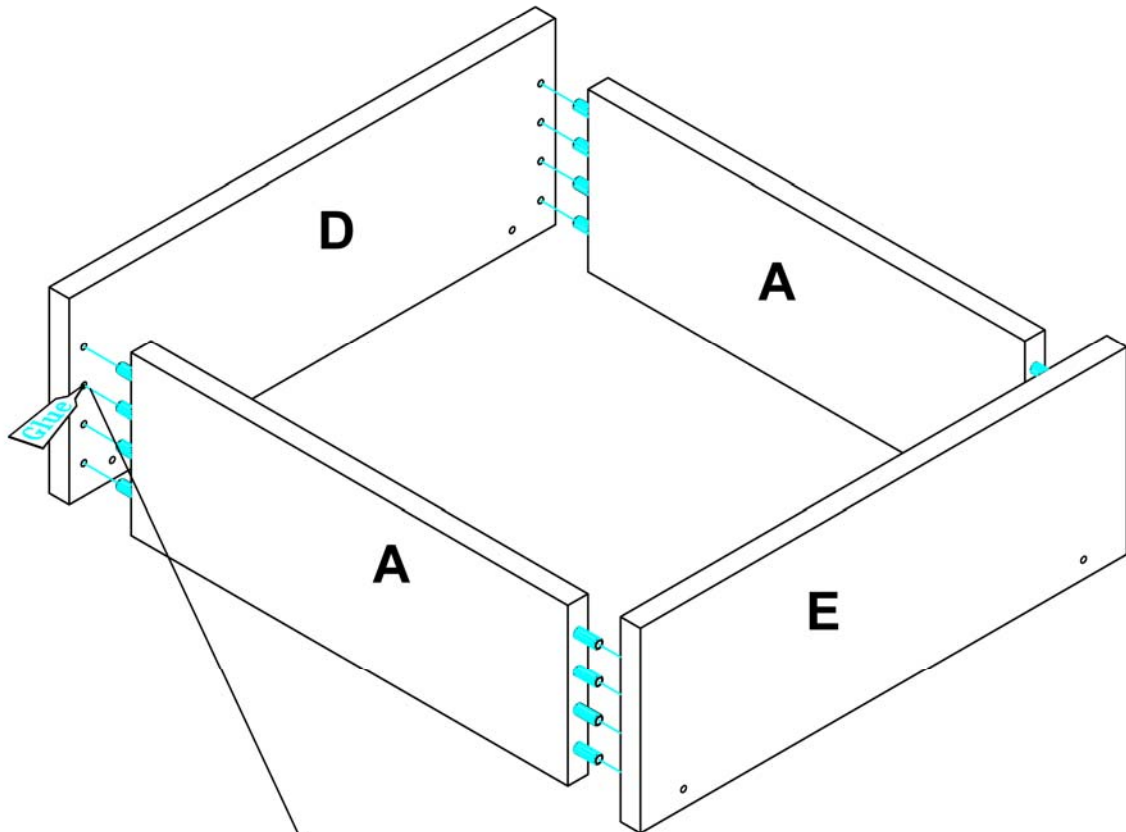

**4**

Attach angle brackets to the wall, use anchors if studs cannot be utilized. Set pins in the holes of metal brackets. Align holes in top with the pins and lower the unit onto them.

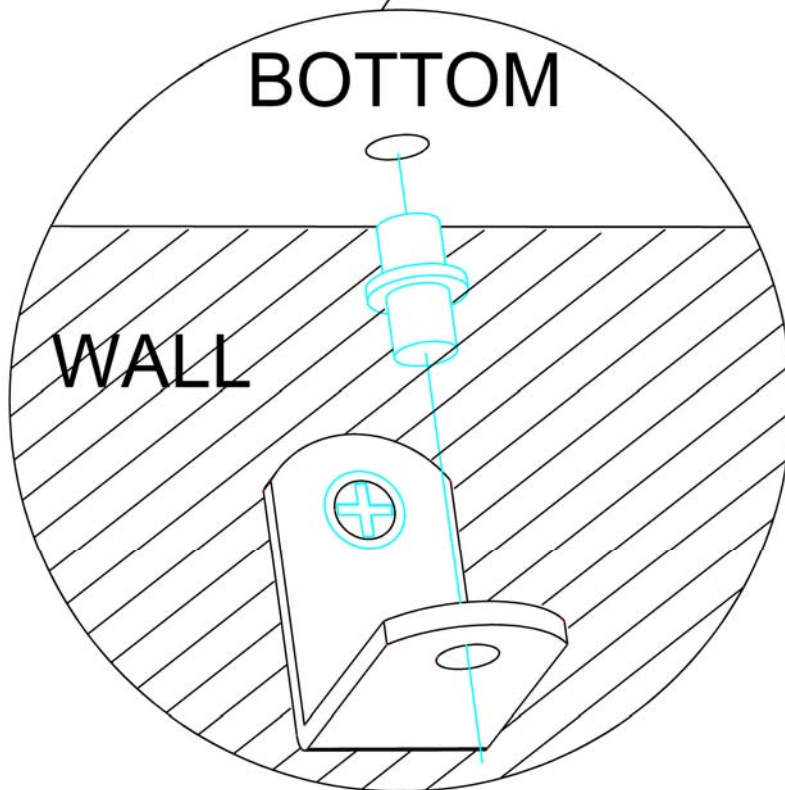
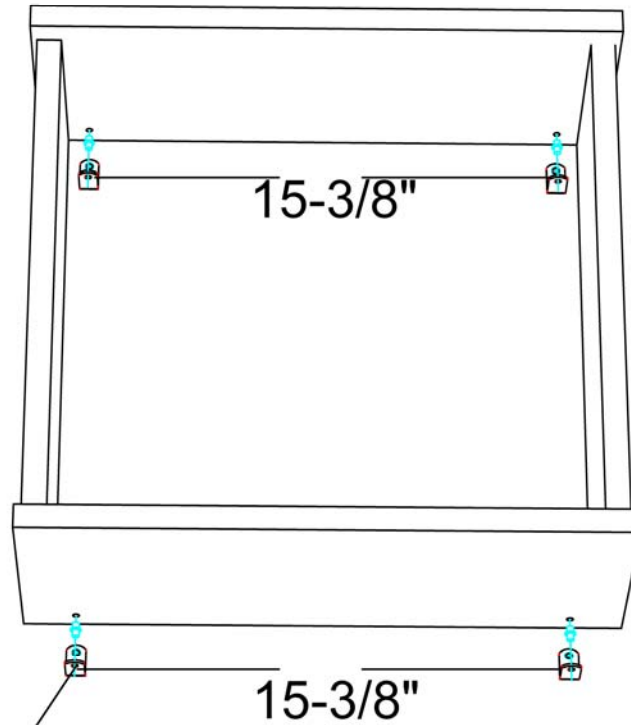

Space brackets exactly  $15\text{-}3/8\text{'}$  apart. You may use brackets attached to the top as a template.

5

