

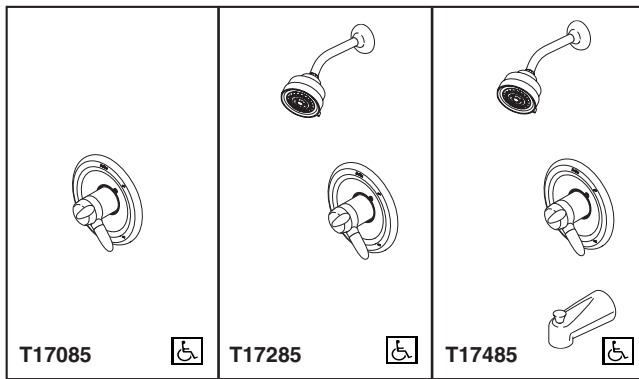

TUB AND SHOWER FAUCET TRIM

- Grail® Bath Collection
- Valve Only (T17085 Series)
- Shower Only (T17285 Series)
- Tub/Shower (T17485 Series)



Submitted Model No.: _____

Specific Features: _____

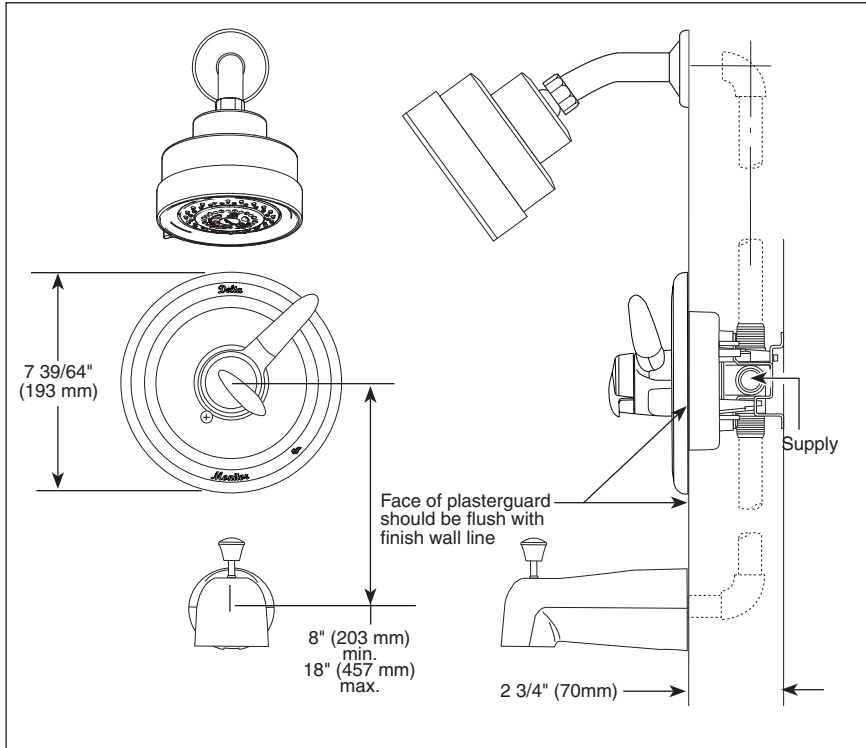

▲ Designate Proper Finish Suffix

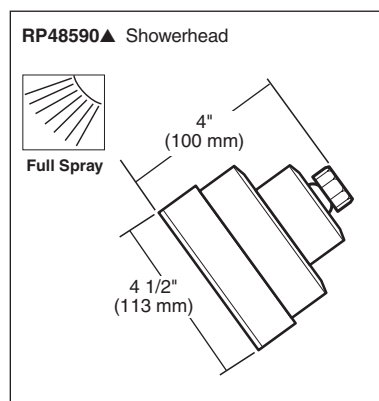
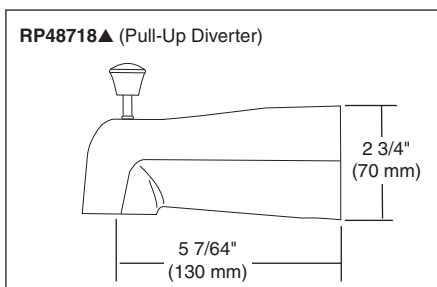

COMPLIES WITH:

- ASME A112.18.1 / CSA B125.1
- Indicates compliance to ICC/ANSI A117.1

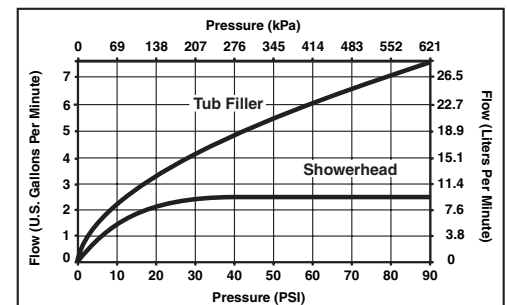

55 E. 111th Street, Indianapolis, Indiana 46280
 350 South Edgewar Road, ST. Thomas, ON N5P 4C4
 © 2010 Masco Corporation of Indiana

Delta reserves the right (1) to make changes in specifications and materials, and (2) to change or discontinue models, both without notice or obligation. Dimensions are for reference only. See current full-line price book or www.specselect.com for finish options and product availability.

DSP-B-T17085 Rev. B