

Assembly Notes

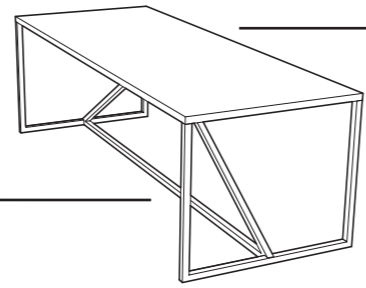

STRUT

Are you

1

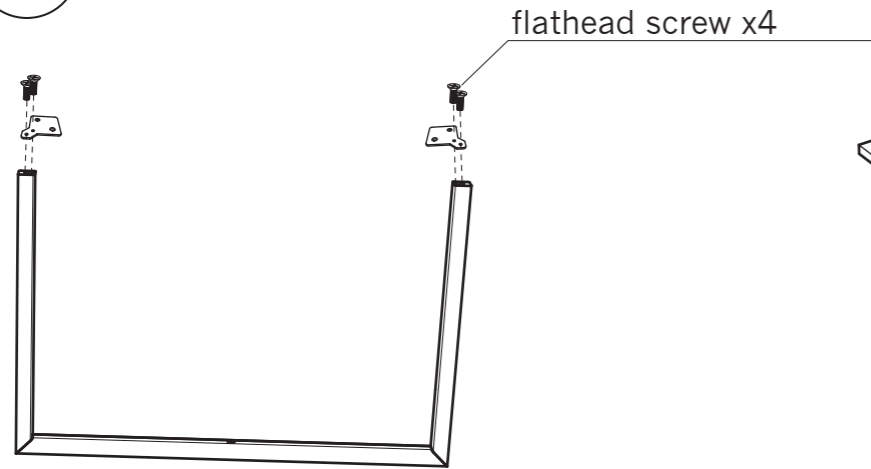

2

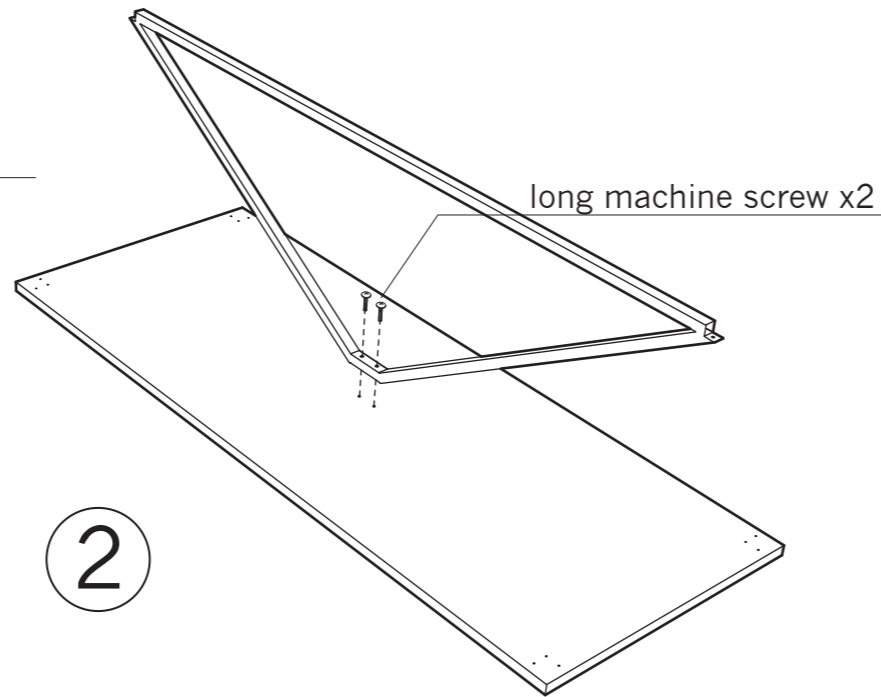

3

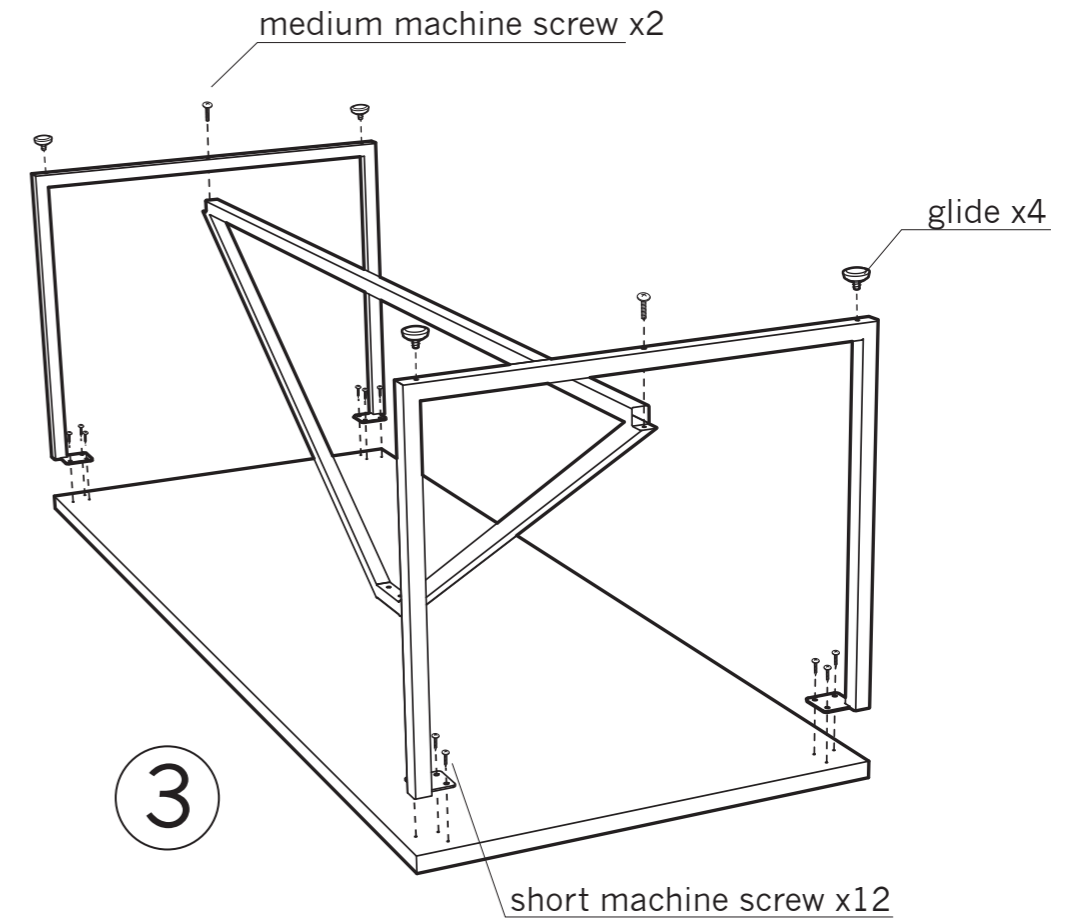

ready to Strut?

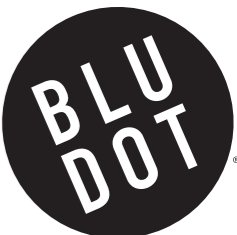

Assemble on carpet or protective mat.

- 1 First, attach the plates to the legs. Orient the legs as shown in Diagram 1. Set the plate onto the end of the leg as shown. Using the hex key, screw the plate securely to the leg with two flathead screws. Repeat for each plate.
- 2 Second, attach the triangular strut to the table top with two long machine screws as shown in Diagram 2. Do not fully tighten the screw. Tighten it just enough so that the strut stands upright by itself.

- 3 Now, using twelve short machine screws, attach the plates to the slots in the table top. Be sure to line up the legs so that they are flush with the edges of the table top. Do not overtighten the screws. Thread a medium machine screw through the center hole in each leg and into both ends of the triangular strut. Now go back and firmly tighten all screws. Lastly, screw the four adjustable glides into the bottoms of the legs. With the help of a friend, flip the table onto its feet. Adjust the glides as necessary to level the table, and admire your reflection in the glossy surface. Aren't you pretty!

HARDWARE INVENTORY



BLU DOT DESIGN AND MANUFACTURING, INC. copyright 2007.
www.bludot.com / t. 612.782.1844 / f. 612.782.1845

REV 2 2007.08.02

SEE CAM ASSEMBLY DETAIL