

# SHELF ADJUSTMENT

Illustration 1

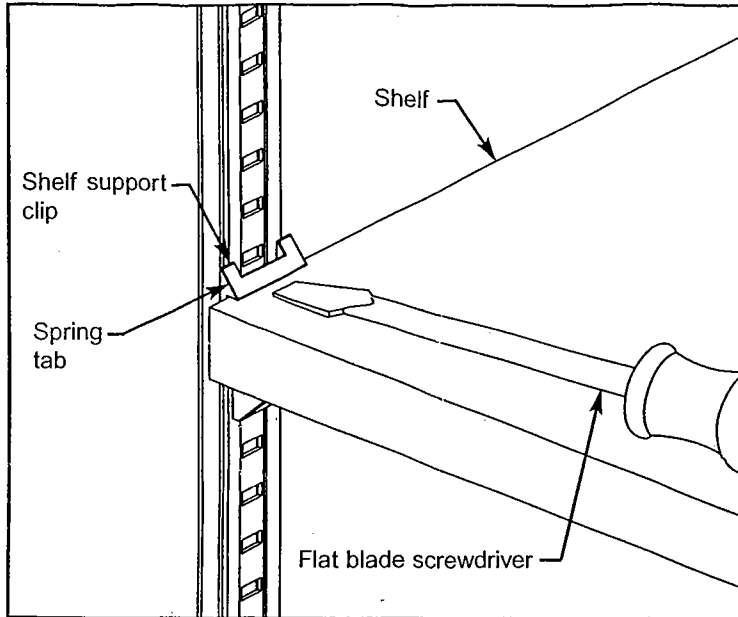
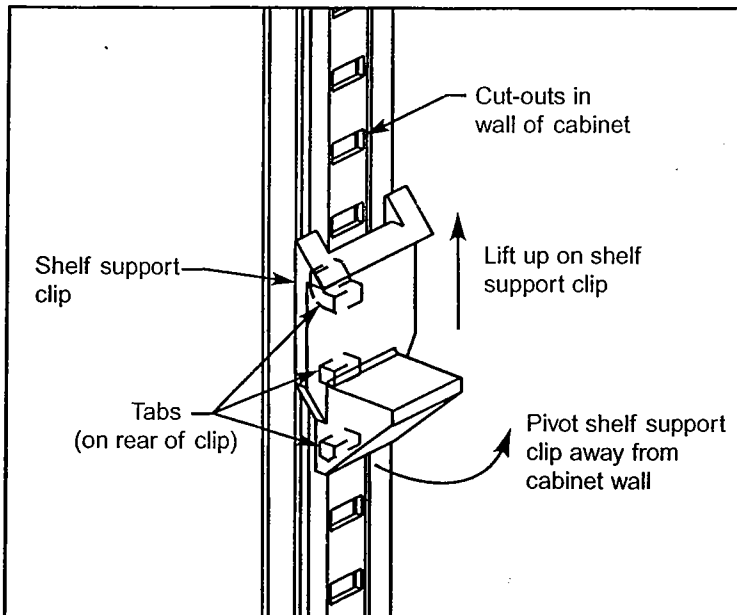

Illustration 2



Read all instructions and review illustrations before installing.

Tools required for assembly:  
Flat blade screwdriver

## ⚠ WARNING

Excessive or concentrated loads can cause a shelf to collapse and cause injury. Do not put more than 180 lbs. distributed load on each shelf.

Sharp edges may cause injury. Take care when handling metal parts.

Shelf Adjustment (refer to Illustration 1):

1. Remove contents from shelf.
2. Locate shelf support clips at each corner of shelf.
3. Refer to Illustration 1. Place end of flat blade screwdriver against shelf support clip spring tab as shown. Carefully press spring tab rearward while lifting corner of shelf. Repeat this procedure for remaining shelf support clips.
4. Lift shelf free of shelf support clips and set aside.
5. Refer to Illustration 2. Lift up on shelf support clip freeing bottom two tabs on rear of clip. Pivot bottom of clip away from cabinet wall and unhook top tab on rear of clip. Repeat this procedure for remaining shelf support clips.
6. Reinstall shelf support clips at desired location. Ensure shelf support clips are level with each other and tabs on rear of clips are fully seated in cabinet cut-outs.
7. Place shelf into shelf support clips.
8. Ensure shelf is fully seated into each shelf support clip and spring tabs are locking shelf into place.

**INSTALLATION INSTRUCTIONS**