

PORTABLE TRAFFIC SECURITY GATE ASSEMBLY INSTRUCTIONS

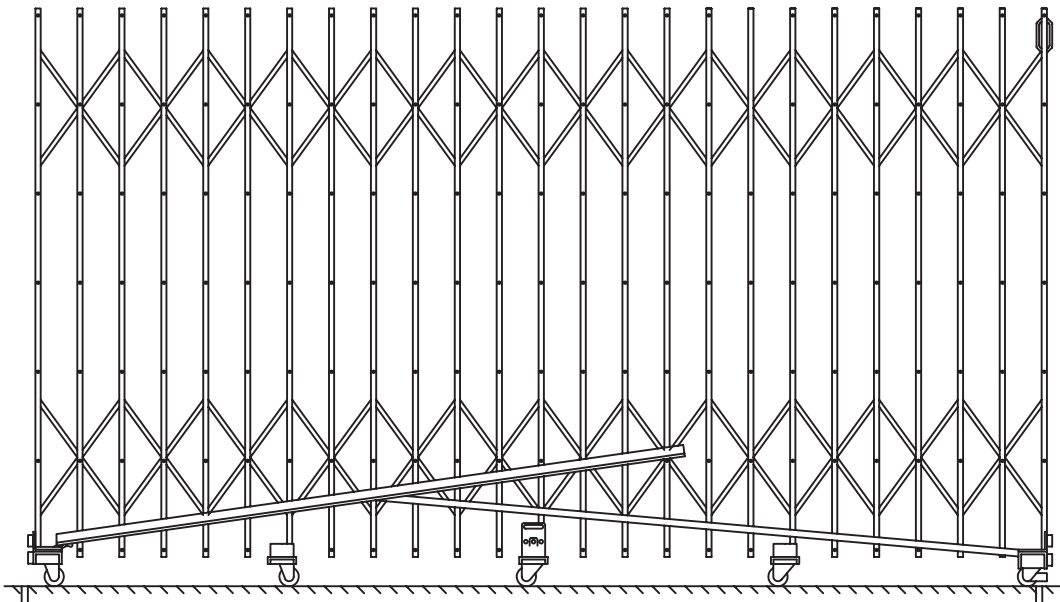

P601 SECURITY GATE

General Instructions

1. Check material received against the packing list. First check the number of packages received and then check the contents of each package.
2. Check material received for damage. If damage has occurred, secure a "damage notation" from the carrier.
3. Identify each part as it is unpacked and put like parts together as close as possible to the working area in which they are to be assembled.
4. Be careful to use the correct hardware as specified in the assembly instructions.
5. Items with suffix (o) are available options.

CAUTION

IN THE INTEREST OF SAFETY, DO NOT ATTEMPT TO INCREASE PRESSURE BY ENGAGING A HOLE MORE DISTANT FROM PIN THAN DESCRIBED IN OPERATING INSTRUCTIONS, OR AN EXCESSIVE AMOUNT OF PRESSURE MAY DEVELOP.

INSTALL ALL UNITS PLUMB AND TIGHTEN ALL HARDWARE SECURELY.
RETAIN INSTRUCTIONS FOR FUTURE REFERENCE.



2823 W. Orange Ave
Apopka, FL 32703

Ph (866) 566-0500
Fax (407) 464-3610

www.hallowell-list.com

PORTABLE TRAFFIC SECURITY GATE ASSEMBLY INSTRUCTIONS

PACKAGE CONTENTS

REF. NO.	DESCRIPTION	PART #	QUANTITY PER WIDTH			
			6' & 9'	12'	15'	18'
x ①	TUBULAR BRACE	P141	4	5	6	7
x ②	CARRIAGE CHANNEL	A3	1	1	1	1
x ③	CARRIAGE CHANNEL	A4	1	1	1	1
x ④	CARRIAGE CHANNEL	A1	1	2	3	4
x ⑤	CARRIAGE CHANNEL	A2	1	1	1	1
xx ⑥	HINGE PIN	P145	3	3	3	3
xx ⑦	7/16" OD SPACER	P155	4	5	6	7
xx ⑧	5/16-13 x 1 3/4" BOLT	P512	4	5	6	7
xx ⑨	5/16-13 HEX CAP NUT	P514	4	5	6	7
xx ⑩	1/2-13 x 3/4 HEX BOLT	P513	4	5	6	7
xx ⑪	CASTER	P151	8	10	12	14
xx ⑫	7/8" OD CASTER SPACER	P156	8	10	12	14
xx ⑬	1/2" LOCK WASHER	P517	12	15	18	21
xx ⑭	1/2-13 HEX NUT	P515	8	10	12	14
xx ⑮	RUBBER BUMPER	P152	8	8	8	8
xx ⑯	1/4-20 x 1" RD HEAD MS	P508	8	8	8	8
xx ⑰	1/4-20 HEX NUT	N107	8	8	8	8
xx ⑱	1/4 EXT. STAR WASHER	W109	8	8	8	8
o ⑲	CYLINDER LOCK	P167	x	x	x	x
o ⑳	LEAD FLOOR ANCHOR	P521	2	2	2	2
o ㉑	ANCHOR SCREW	P510	2	2	2	2
㉒	-	-	-	-	-	-

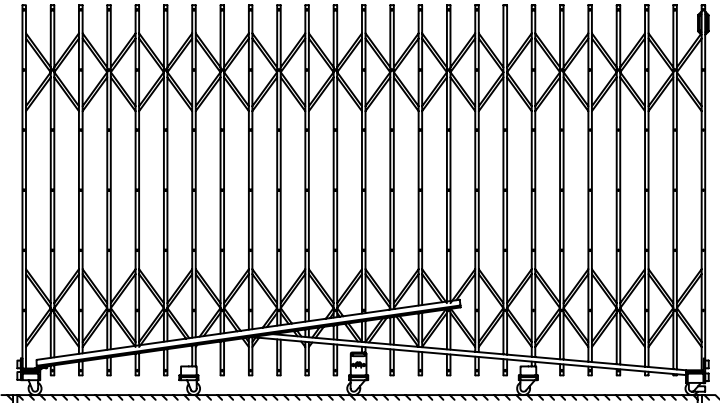

MODEL NO.	OPENING SIZE
P601-6	3'-6" TO 6" 0"
P601-9	6'-0" TO 9'-0"
P601-12	7"-0" TO 12'-0"
P601-15	11'-0" TO 15'-0"
P601-18	13'-0" TO 18'-0"

NOTE:

- x SHIPS IN BOX #2
- xx SHIPS IN BOX #1 LOCATED INSIDE BOX #2

OPTIONAL ITEMS

- o CYLINDER LOCK ⑲ CAN BE KEYED ALIKE, CUSTOMER TO SPECIFY.
- o TO BE INSTALLED BY CUSTOMER.

TWO-YEAR WARRANTY

HALLOWELL SECURITY GATES ARE COVERED AGAINST ALL DEFECTS IN MATERIALS AND WORKMANSHIP EXCLUDING FINISH, DAMAGE RESULTING FROM DELIBERATE DESTRUCTION AND VANDALISM FOR A PERIOD OF TWO YEARS.



SECURITY GATE ASSEMBLY INSTRUCTIONS

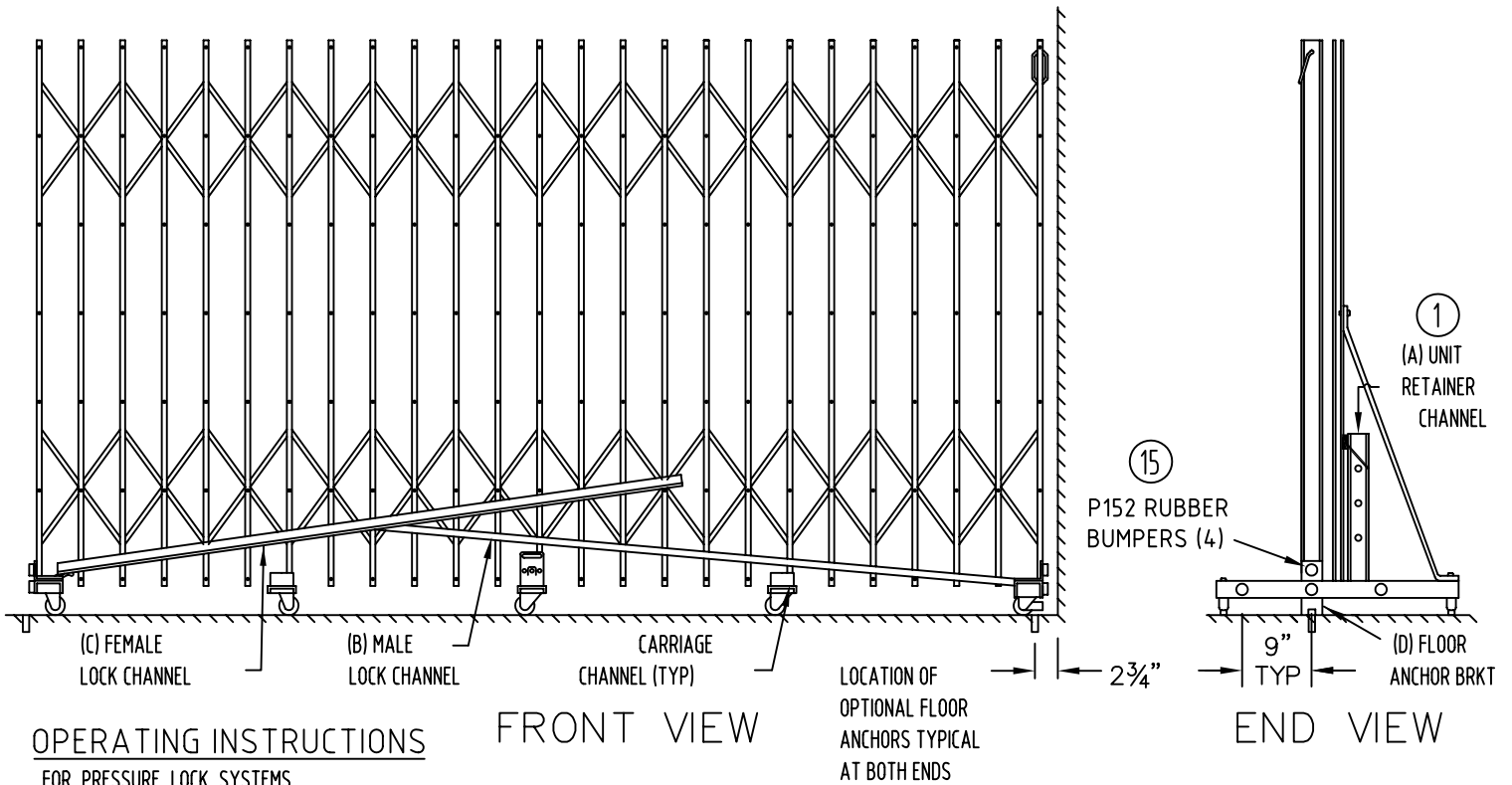

- 1 RAISE UNIT RETAINER CHANNEL (A) TO VERTICAL POSITION & SECURE.
- 2 EXTEND GATE UNTIL RUBBER BUMPERS TOUCH THE WALLS.
- 3 LOWER THE MALE LOCK CHANNEL (B) (WITH PIN) UNTIL IT RESTS ON CARRIAGE CHANNELS WITHIN GUIDES AND LOCKING BRACKET.
- 4 LOWER FEMALE LOCK CHANNEL (C) (WITH ADJUSTMENT HOLES) UNTIL IT RESTS WITHIN MALE LOCK CHANNEL. DO NOT ENGAGE A HOLE IN FEMALE LOCK CHANNEL.
- 5 RAISE BOTH CHANNELS (BEING CAREFUL TO AVOID PINCHING HANDS) UNTIL PIN ENGAGES THE HOLE IMMEDIATELY TO THE RIGHT OF PIN. APPLYING MODERATE PRESSURE, PUSH BOTH CHANNELS DOWN UNTIL THEY REST WITHIN GUIDES AND LOCKING BRACKET. PADLOCK IN POSITION.

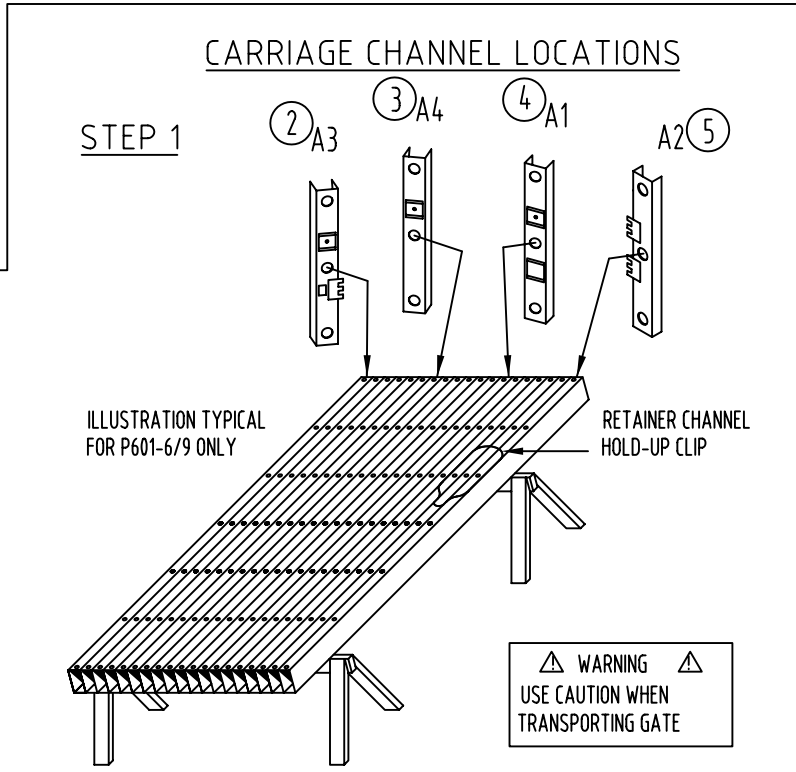

CARRIAGE CHANNEL SELECTION GUIDE

MODEL SIZE	AMOUNT OF CHANNELS	END VIEW OF GATE BODY SHOWING THEIR PLACEMENT
P601-6 (3'-6" TO 6'-0")	4	A2 A1 A4 A3
P601-9 (6'-0" TO 9'-0")	4	A2 A1 A4 A3
P601-12 (7'-0" TO 12'-0")	5	A2 A1 A4 A1 A3
P601-15 (11'-0" TO 15'-0")	6	A2 A1 A4 A1 A1 A3
P601-18 (13'-0" TO 18'-0")	7	A2 A1 A4 A1 A1 A1 A3

- A. PLACE GATE BODY ON WORK SURFACE SO THAT SINGLE WIRE HOLD-UP CLIP FOR UNIT RETAINER CHANNEL IS UP.
- B. USING CARRIAGE CHANNEL SELECTION GUIDE, SELECT CARRIAGE CHANNELS & ATTACH TO GATE BODY AS SHOWN FOR GATE SIZE ORDERED.



SECURITY GATE ASSEMBLY INSTRUCTIONS

STEP 2

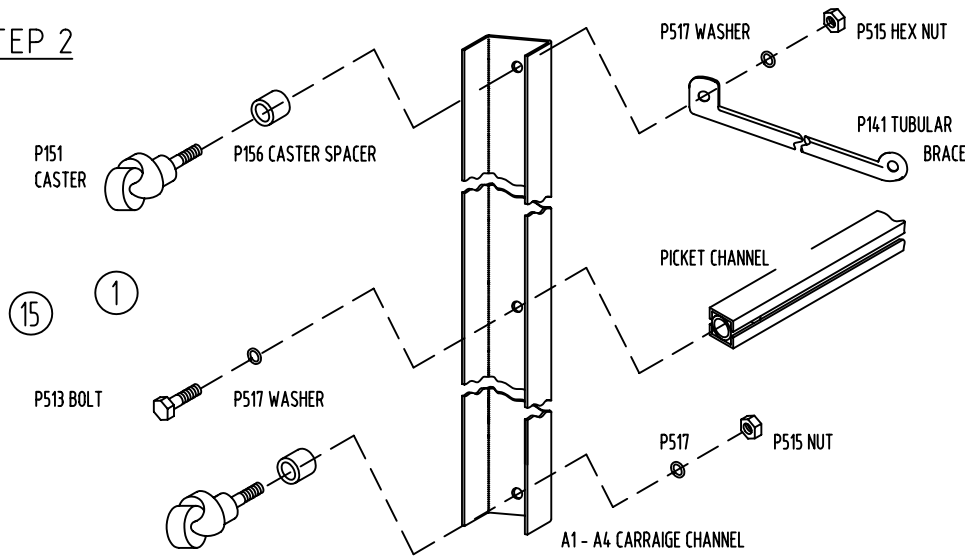

ATTACH THE CARRIAGE CHANNELS

BOLT THE CARRIAGE CHANNELS TO THE GATE BODY WITH $\phi 1/2-13 \times 3/4$ " HEX BOLTS AND LOCK WASHER. ATTACH CASTERS & TUBULAR BRACE TO THE CARRIAGE CHANNELS

VERY IMPORTANT NOTE:
ALL CARRIAGE CHANNELS MUST BE 90° TO THE GATE BODY BEFORE TIGHTENING.

STEP 3 BRACE UPRIGHT

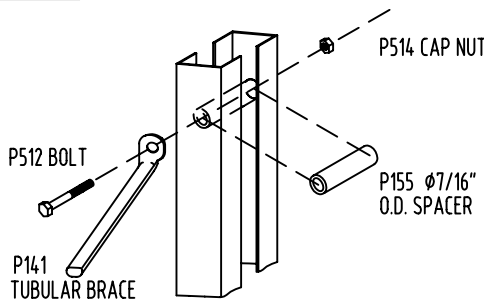

SET GATE ON FLOOR IN UPRIGHT POSITION AND EXTEND GATE TO ENABLE PLACEMENT OF $\phi 7/16$ O.D. SPACER BETWEEN PICKET CHANNELS. HOLDING THE SPACER IN PLACE, THREAD TUBULAR BRACE, PICKET CHANNELS, AND SPACER WITH $\phi 5/16 \times 1-3/4$ " HEX HEAD CAP BOLT AND SECURE WITH $\phi 5/16$ " CAP NUT.

STEP 4 ATTACH UNIT RETAINER AND LOCK CHANNELS

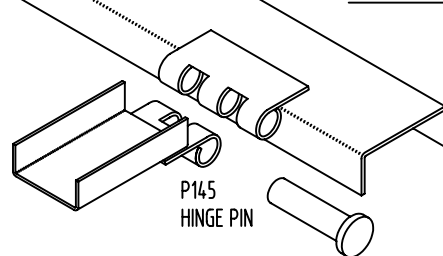

- A. ON BRACED SIDE OF GATE, ATTACH UNIT RETAINER CHANNEL BY INSERTING HINGE PIN.
- B. FACING LOCK SIDE OF GATE, ATTACH MALE CHANNEL ON RIGHT HAND SIDE SO THAT PIN WILL POINT UPWARDS WHEN IT IS IN LOCKED POSITION.

C. INSTALL FEMALE LOCK CHANNEL ON LEFT HAND SIDE SO THAT HOLE WILL BE DOWN WHEN IN LOCKED POSITION.

- D. INSTALL FOUR RUBBER BUMPERS ON EACH SIDE OF GATE WITH A $\phi 1/4$ "-20 PHILLIPS SCREW (P508.) INSERT BY FORCING HEAD INTO LARGE HOLE OF RUBBER BUMPER, UNTIL THREAD EXTENDS OUT OF OPPOSITE END. SELECT PROPER HOLES 9" FROM CENTERLINE (SEE GATE END VIEW ABOVE) OF LOCKING CHANNELS & HOLE IN BUMPER MOUNT. SECURE BUMPERS WITH $\phi 1/4$ " NUT.

STEP 5 (OPTIONAL) INSTALL FLOOR ANCHORS

DRILL $\phi 7/8$ HOLE 1-1/4" DEEP IN CONCRETE FLOOR, 2-3/4" AWAY FROM WALL AND SET ANCHOR. THREAD 1/2" TRUSS HEAD MACHINE SCREW INTO EACH ANCHOR, TURNING UNTIL TOP OF BOLT IS FLUSH TO FINISH FLOOR.

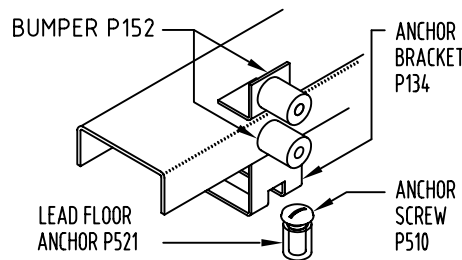

STEP 6 (IF OPTIONAL)

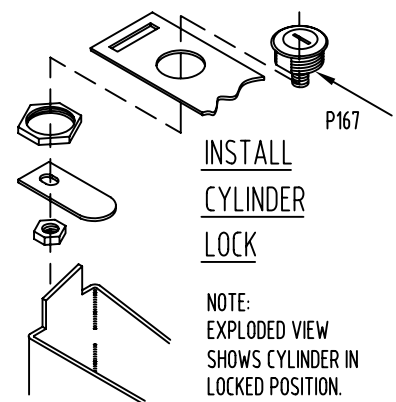

INSTALL CYLINDER LOCK

NOTE: EXPLODED VIEW SHOWS CYLINDER IN LOCKED POSITION.

HALLOWELL MAKES EVERY EFFORT TO ENSURE THAT ALL UNITS SHIP COMPLETE. HOWEVER, SHOULD YOUR UNIT CONTAIN MISSING OR DAMAGED PARTS, REPLACEMENTS MAY BE OBTAINED FROM HALLOWELL. TO OBTAIN PARTS, FOLLOW THESE INSTRUCTIONS.

PLEASE PROVIDE THE FOLLOW INFORMATION:

- | | |
|---|--------------------------------------|
| MODEL NUMBER | PURCHASE DATE |
| DESCRIPTION OF PART(S) NEEDED & PART NUMBER(S) AS SHOWN IN PARTS LIST | COMPANY NAME & CONTACT PERSON |
| COLOR | WHERE THE PRODUCT WAS PURCHASED FROM |
- IF REQUESTING PARTS BY TELEPHONE, ASK FOR CUSTOMER SERVICE & PROVIDE THE ABOVE INFORMATION.

