

# Flip Top CAFE Table

Model FT36RD 36" Round

Model FT36SQ 36" Square

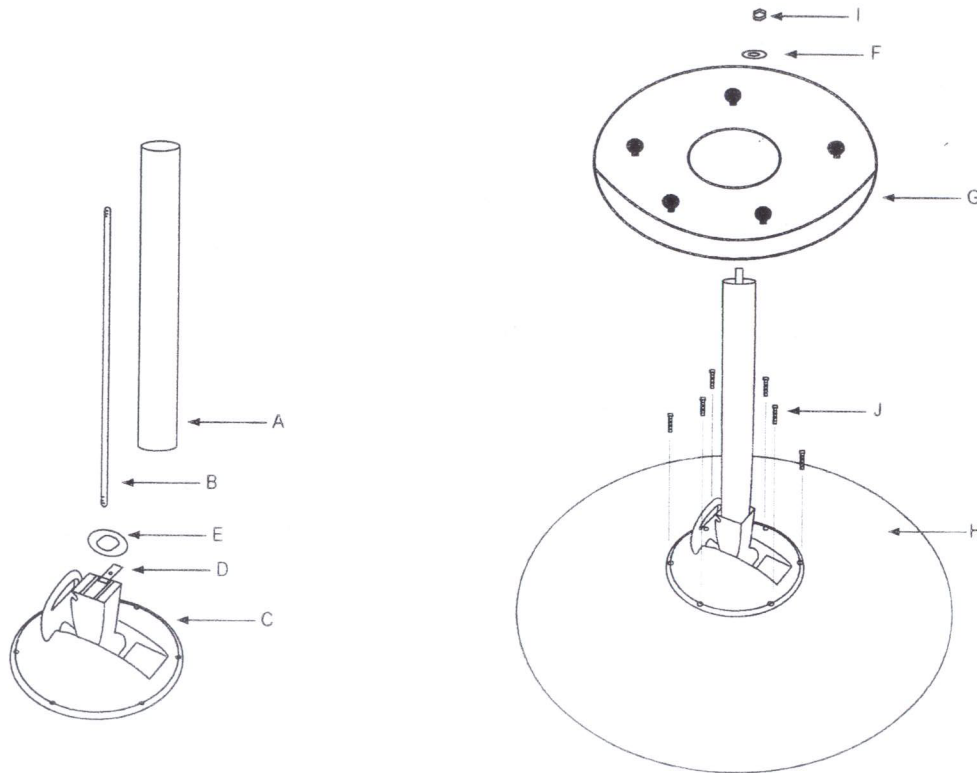

## Assembly Instructions

**Step 1:** Place Base Mechanism (C) on to flat surface.

**Step 2:** Latch Base Mechanism (C) in upright position.

**Step 3:** Slide Metal Insert (D) into groove on base mechanism and attach Plastic Cap (E).

**Step 4:** Screw Rod (B) through Metal Insert (D) and Plastic Cap (E) into Base Mechanism (C).

**Step 5:** Place Cylinder (A) over Rod (B).

**Step 6:** Set R-Base (G) through end of Rod (B). place Washer then Spacer (F) and screw on Bolt (I) tightly.

**Step 7:** Place Table Top (H) on flat non-scratching surface. Invert base unit and align with matching holes. Insert and tighten 6 bolts (J).

**Step 8:** Return to upright position. Unhook latch to fold top down. Use built-in handle to carry table.

## Parts List

- 1 - Cylinder (A)
- 1 - Rod (B)
- 1 - Base Mechanism (C)
- 1 - Metal Insert (D)
- 1 - Plastic Cap (E)
- 1 - Washer with Spacer (F)
- 1 - R-Base (G)
- 1 - Table Top (H)
- 1 - Nut for Rod (I)
- 6 - 1/4" x 3/4" Bolts (J)

**ofm**<sub>U</sub>  
Z  
Furniture For The Real Office™

161 Tradition Trail Holly Springs, NC, 27540  
800-520-7471 (voice) 919-362-4765 (fax)  
919-303-6389 (voice) www.ofminc.com  
support@ofminc.com