

# Model 595-F / 595-L Ultimate Executive Fabric/Leather & Mesh Guest Chair

## Parts Listing

A  
Chair Back  
1 Unit

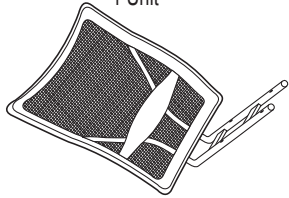

B  
Chair Seat  
1 Unit

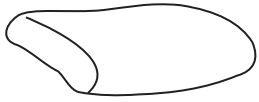

C  
Chair Base  
1 Unit



D  
Chair Arms  
2 Units



E  
Large Washer  
2 Units



F  
Small Washer  
14 Units



G  
8x45mm Screw  
4 Unit



H  
8x25mm Screw  
4 Units



I  
Arm Screws  
6 Units

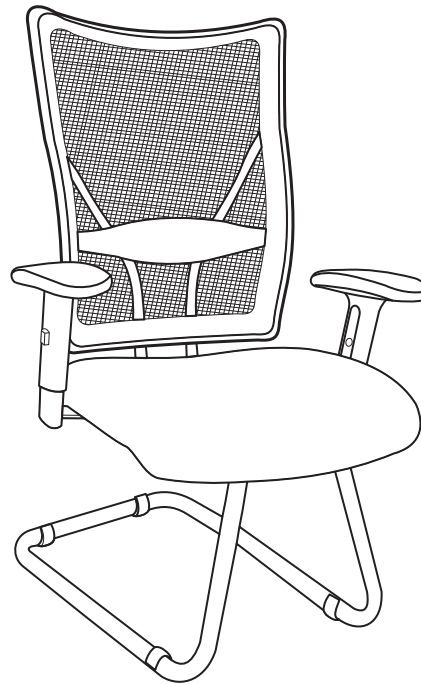
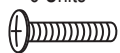

## Assembly Instructions



**Tools Needed: Phillips Head Screwdriver**  
*Please read all instructions before assembly.*

- Step 1:** Attach Chair Arms (D) to Chair Seat (B) by placing Large Washers (E) between the Chair Seat (B) and the Chair Arms (D), aligned with the inside hole on arms. Then with one Small Washer (F) on each Arm Screw (I), insert screws through the holes in the Chair Arms (D) and into the Chair Seat (B).
- Step 2:** Attach Chair Base (C) to Chair Seat (B) by inserting four 8x25mm Screws (H), with Small Washers (F) through holes in the crossbars of the Chair Base (C) and into the Chair Seat (B).
- Step 3:** Attach Chair Back (A) to Chair Seat (B) by inserting three 8x45mm Screws (G), with Small Washers (F), through bars and into the Chair Seat (B).

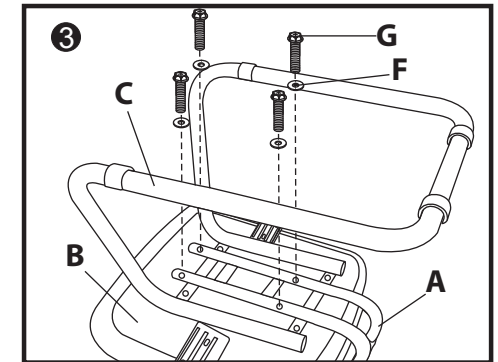
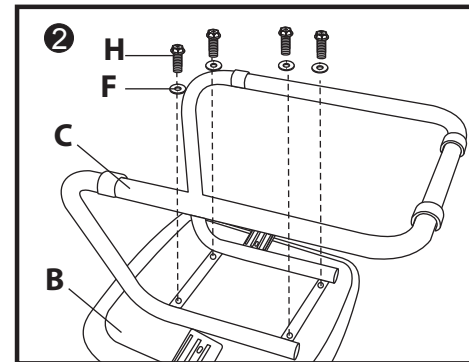
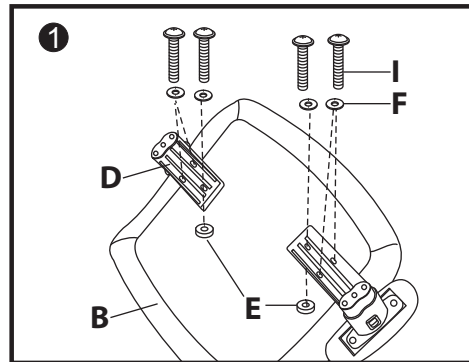

**WEIGHT CAPACITY: 250 lbs.**

### Assembly Notes:

During assembly, hand tighten screw only when all screws are in place, you may then tighten all screws completely.

### CAUTION:

1. Do not use this chair as a step ladder.
2. Check for loose screws and tighten them every 6 months.

**ofm**  
Furniture For The Real Office™

161 Tradition Trail Holly Springs, NC, 27540  
800-520-7471 (voice) 919-362-4765 (fax)  
919-303-6389 (voice) www.ofminc.com  
support@ofminc.com