

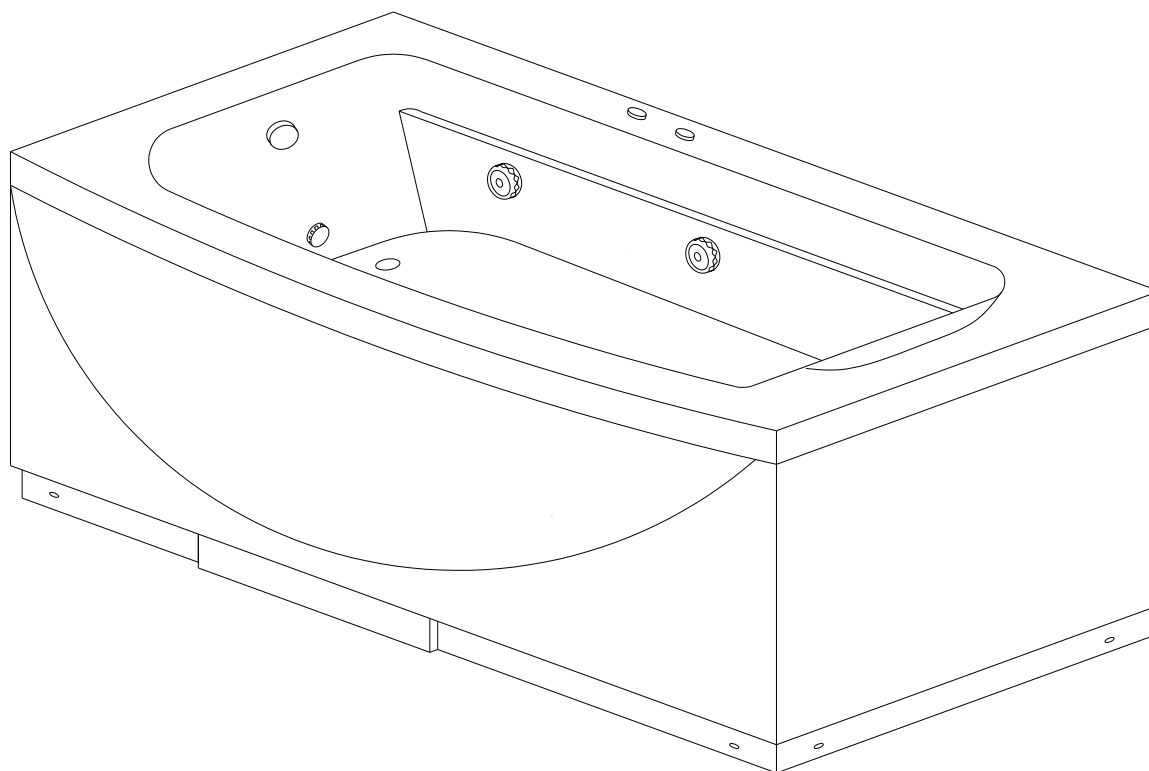

## INSTALLATION AND OWNER'S MANUAL



Whirlpool Bathtub Model Number: **A601-L**

Please carefully read these instructions before you begin to install the products.

07/11 Rev A  
P/N:100056-01

# Before you start

Thank you for purchasing your Aston whirlpool bathtub. We hope that it will provide you with years of satisfying use and enjoyment.

Please read this manual carefully because it contains information and instructions about the proper installation of the unit. If you do not follow certain conditions of installation and maintenance, your warranty may be affected.

Aston whirlpool bathtubs feature:

- Air switch pump control
- Massaging whirlpool jets
- Easy maintenance durable fiberglass reinforced acrylic
- Air control knob

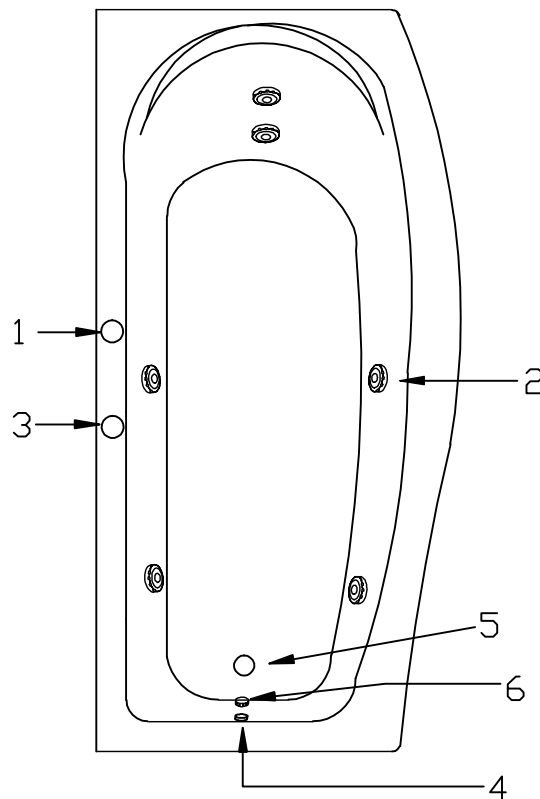

- 1. Air conditioner
- 2. Whirlpool Jets
- 3. Air switch

- 4. Overflow
- 5. Drain
- 6. Suction cover

# Important Safety Instruction

**WARNING:** To reduce the risk of drowning, electrical shock, or injury, read the following important precautions before using the unit. If you do not fully understand the meaning of any of the precautions and warnings please consult your dealer or the manufacturer for a full explanation. Do not use the unit until you understand all of the following:

1. **WARNING:** Read and follow all instructions.
2. **DANGER:** To reduce the risk of injury, do not permit children to use the unit unless they are closely supervised.
3. **WARNING:** Use this unit only for the intended purpose described in this manual; do not use attachments not recommended by the manufacturer.
4. **WARNING:** Never drop or insert any objects into any opening.
5. **WARNING:** The unit must be connected to a supply circuit that is protected by a ground fault circuit interrupter (GFCI). This GFCI should be provided by the installer and routinely tested.

To test the GFCI:

- a. Push the "test" button. The GFCI should interrupt the power going to the unit.
- b. Press the "reset" button and power should be restored.

If the GFCI fails to operate as described, the GFCI is defective and must be replaced. If the GFCI interrupts power to the unit without the test button being pushed, a ground fault has occurred. Discontinue use and contact your dealer or service provider.

6. **WARNING:** If you have a pre-existing health condition such as obesity, heart disease, high or low blood pressure, circulatory problems, or diabetes, consult your physician before use. If you are pregnant or could be pregnant, do not use the unit without consulting your doctor.
7. **WARNING:** Observe reasonable time limits when using this product. Long exposures at high temperatures can cause high body temperatures. Symptoms may include dizziness, nausea, fainting, drowsiness, and reduced awareness. These effects could possibly lead to drowning.
8. **WARNING:** The water jets produce a stream of water with relatively high pressure. Prolonged exposure of high-pressure water to a localized area of the body may cause bruising.
9. **WARNING:** Prolonged immersion in hot water or steam may induce hyperthermia. A description of the cause, symptoms and effects of hyperthermia are as follows:
  - a. Lack of awareness of impending hazard;
  - b. Failure to perceive heat;
  - c. Failure to recognize the need to exit the unit;
  - d. Fetal damage in pregnant women;
  - e. Unconsciousness and danger of drowning.

- 10. WARNING:** To avoid the risk of accidental injury or drowning children should not use the hydro massage bathtub without adult supervision.
- 11. WARNING:** To avoid injury, take care when entering or exiting the hydro-massage bathtub.
- 12. WARNING:** To avoid unconsciousness and possible drowning, do not take drugs or drink alcohol before or during the use of a hydro massage bathtub equipped with a heater.
- 13. WARNING:** To prevent risk of fetal injury, a pregnant or possibly pregnant woman should consult a doctor before using a hydro massage bathtub equipped with a heater.
- 14. WARNING:** To reduce the risk of hyperthermia and possible drowning, do not use a hydro massage bathtub equipped with a heater immediately following strenuous exercise.
- 15. WARNING:** To reduce the risk of electric shock, do not permit electric appliances (such as a hair dryer, lamp, telephone, radio, or television) within 1.5m (5 ft.) of a hydro massage bathtub.
- 16. CAUTION:** Test the ground fault circuit interrupter (GFCI) protecting this appliance periodically in accordance with the manufacturer's instructions.
- 17. WARNING:** Water temperature in excess of 40°C (104°F) may be injurious to your health and increase the risk of hyperthermia and drowning.
- 18. WARNING:** To reduce the risk of hyperthermia, people using medication and or having an adverse medical history should consult a doctor before using a hydro massage bathtub equipped with a heater.

# Installation Guide

Please read and follow the installation instructions and guidelines in this section. Failure to follow the recommended instructions and installation techniques may lead to possible damage to the unit or the surrounding area and can affect warranty claims.

**ATTENTION:** This unit requires assembly. A minimum of two people are required for assembly, as several of the sections can be large and unstable until assembled.

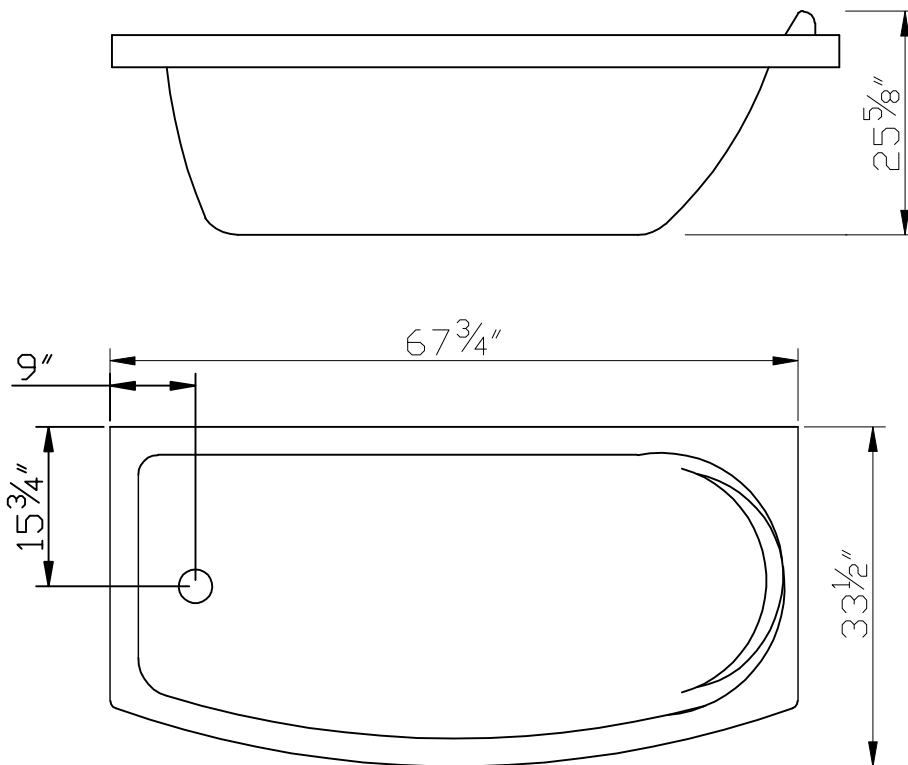

**You will need the following tools:**

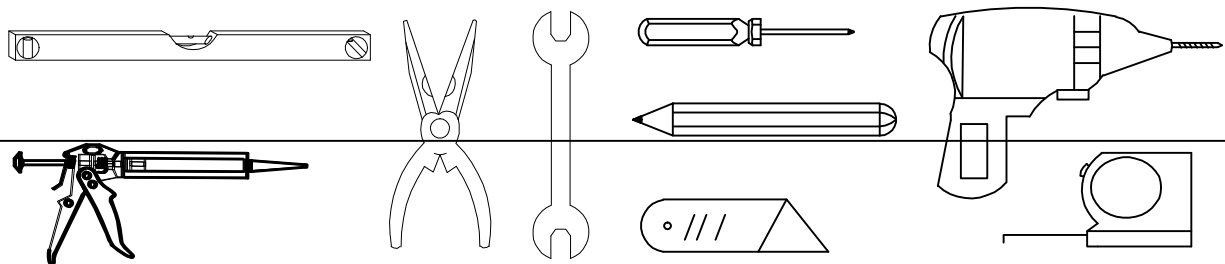

- Drill with screwdriver attachments
- Caulk gun
- Level (3 foot or longer is recommended)
- Tape measure

- **Phillips head screw driver**
- **Bathroom rated silicone sealant**

### **Electrical Requirements**

- **Installation by a Licensed Electrician**
- **15 Amp service, 110-120 VAC @ 60Hz**
- **GFCI breaker required**

**Before starting the installation, please ensure that you have inspected all components of the unit and check for broken or damaged sections. If you find damage, please contact your dealer or the manufacturer.**

# Remove the whirlpool tub skirt for access

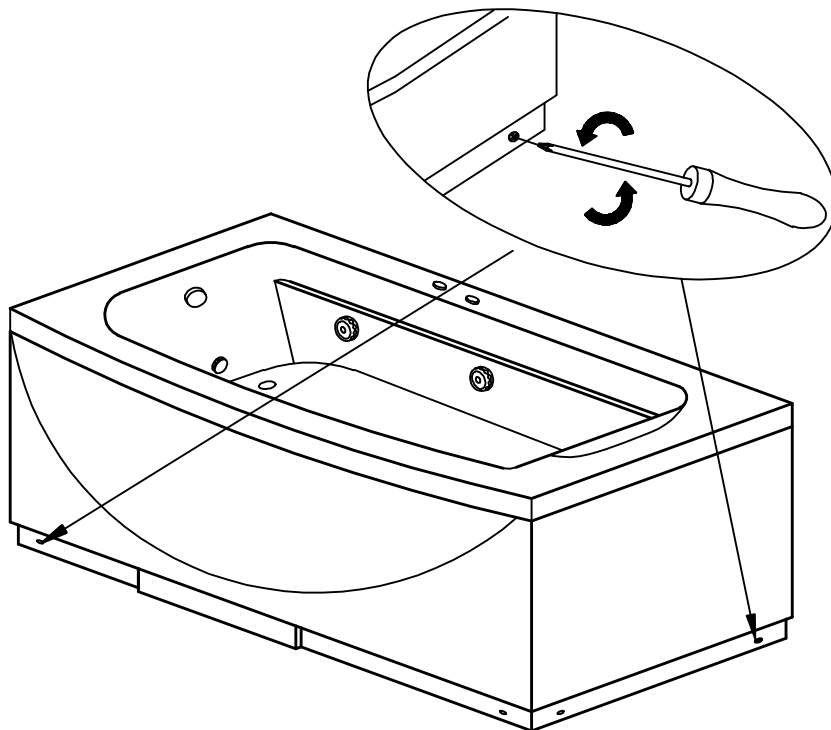

Using a Phillips screw driver to remove the screws holding the skirt onto the whirlpool tub

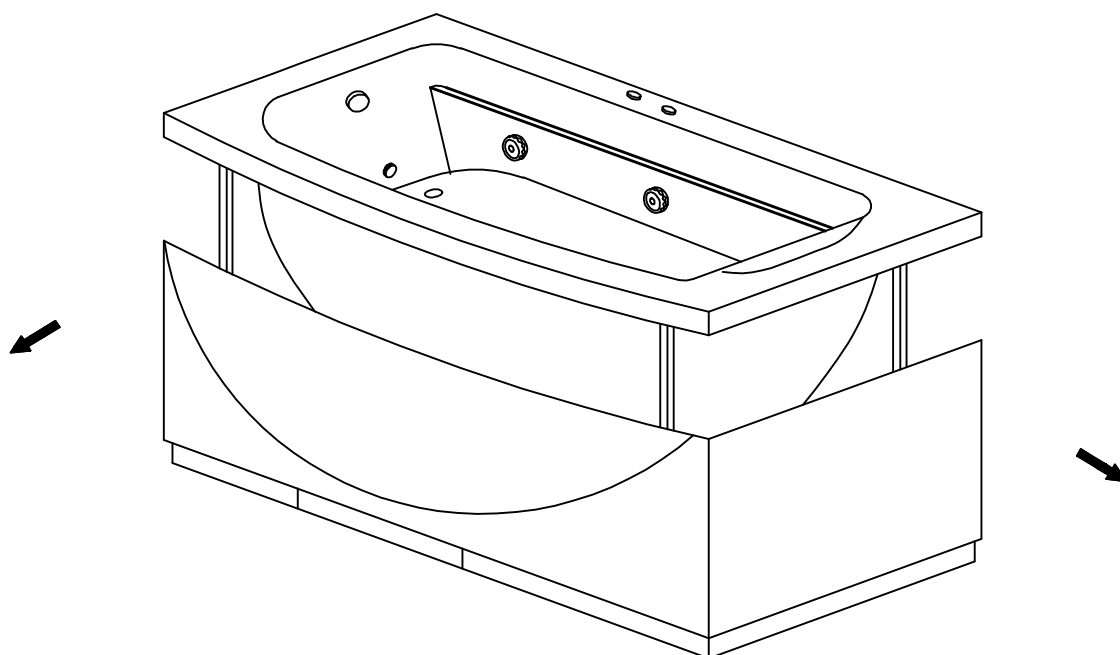

To remove the skirt but pulling down on the skirt carefully

# Level the whirlpool bath for proper drainage

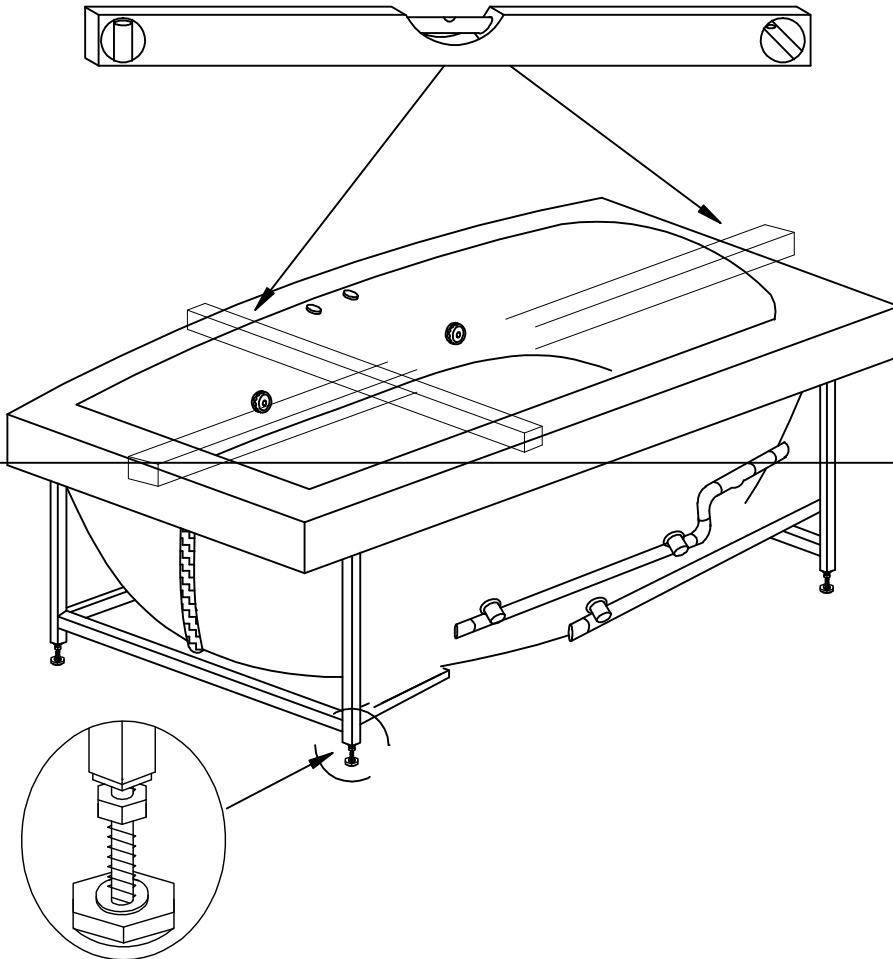

The whirlpool bath is constructed with several leveling feet. Each foot has a locking nut. Use an adjustable wrench and level to complete this next step.

1. Loosen all of the locking nuts so that the leveling feet are free and easy to move.
2. Place the whirlpool bath into the exact final installation location or a flat surface.
3. Place the level across the top of the whirlpool bath (side to side) and level the whirlpool bath by adjusting the leveling feet.

**NOTE:** You may need to remove the whirlpool bath in order to adjust the leveling feet, but always recheck the level with the unit in the final installation location.

4. Place the level across the top of the base (front to back) and level the base by adjusting the leveling feet.

**WARNING:** Failure to apply proper pitch or grade for drainage can cause leaking and/or flooding of the area surrounding the unit.

5. After making all the leveling adjustments ensure that all leveling feet (including center foot) are in contact with the floor. To ensure the unit is supported, stand in the whirlpool bath in several places looking for any movement and adjust as needed.
  6. After ensuring all leveling feet are in contact with the floor, tighten the locking nut on each leveling foot ensuring that all leveling feet are secure.
  7. Once all the leveling feet are secure, place the whirlpool bath back into the final installation location and verify all the leveling adjustments remain as before. Adjust as needed.
-

# Optional drain connections

The Whirlpool tub comes equipped with a factory installed drain and overflow and an optional flexible drain hose is also provided to avoid having to move the floor drain.

Please see the Drain diagram for the optional drain hose.

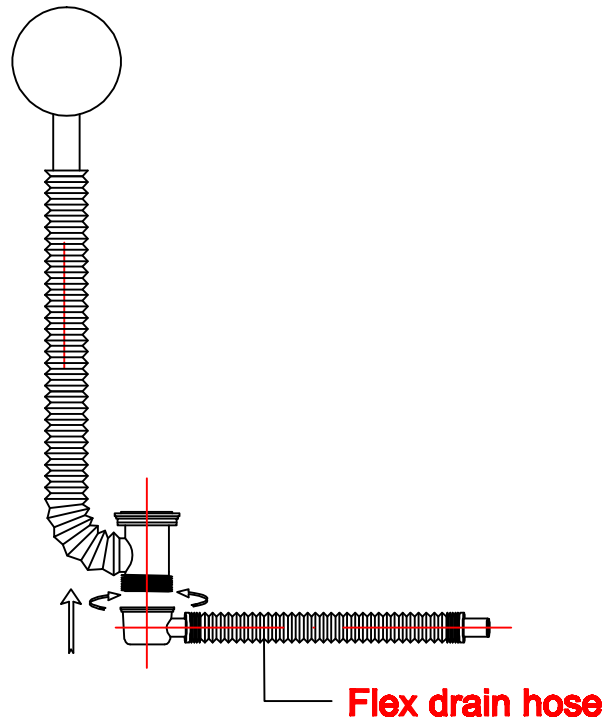

Use the following instructions for the standard straight drain:

1. Move the floor drain so that the floor drain and whirlpool tub drain are in line when the whirlpool tub is in its final position
2. With the whirlpool tub in its final location make the plumbing connections between the whirlpool tub and the floor drain.

Use these instructions for installation of the optional floor drain:

1. Apply sealant to the drain hose gasket and into the compression nut.
2. Install the hose, compression nut, and gasket assembly onto the lower drain body.
3. Tighten the compression nut so that the gasket is compressed creating a positive seal.

# Electrical Connection

With the skirt removed make the final electrical connections. The unit **MUST** be connected to a GFCI protected circuit.

## Install the whirlpool tub skirt

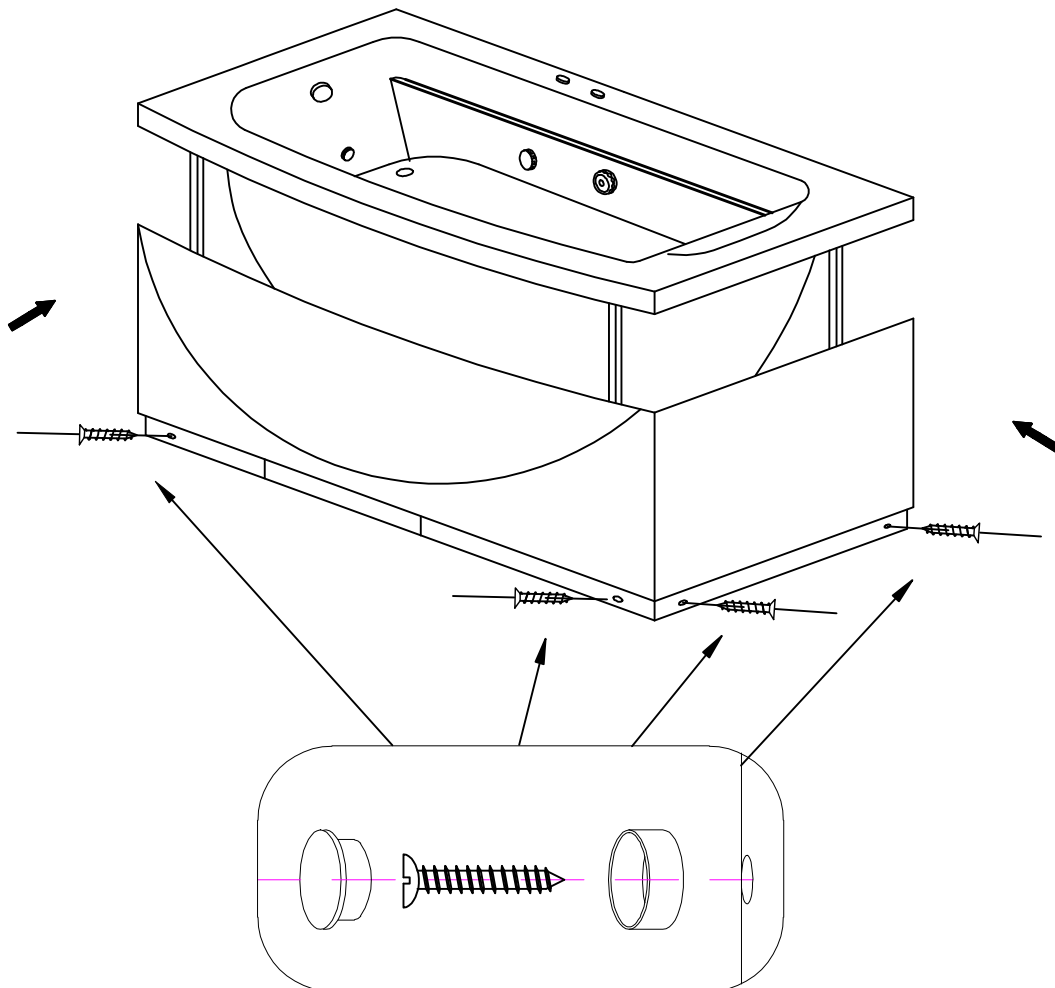

**Slide the skirt into place and fasten with screws provided**

# Operation of the whirlpool tub

**WARNING:** Never operate the whirlpool pump with out water above the suction cover this will damage the pump and void the warranty.

Use the following steps to operate the whirlpool tub:

1. Fill the tub with water until the whirlpool jets are covered
2. Press the air button to turn on the whirlpool jets
3. You can use the air control knob to adjust the whirlpool jet pressure by adding or removing air.
4. Press the air button to turn off the whirlpool jets

# Troubleshooting

<b>Symptoms</b>	<b>Possible Causes</b>	<b>Solutions</b>
<b>No power to unit</b>	<b>1. Loose power connections 2. GFCI Breaker tripped</b>	<b>1. Verify and check all power connections 2. Reset GFCI, if GFCI keeps tripping replace pump</b>
<b>Whirlpool jets not working</b>	<b>1. No power to pump 2. Pump issue</b>	<b>1. Verify power to the unit, Check GFCI 2. Bad pump replace if necessary</b>

# Warranty

**PLEASE READ THESE WARRANTY TERMS AND CONDITIONS CAREFULLY BEFORE USING YOUR ASTON GLOBAL BATHROOM PRODUCT. BY USING THE PRODUCT, YOU ARE CONSENTING TO BE BOUND BY THE FOLLOWING WARRANTY TERMS AND CONDITIONS.**

## **Aston Global Inc. Parts-Only Limited Warranty**

Aston Global, Inc. ("Aston Global") warrants to the original retail purchaser ("Owner") of any bathroom products or bathroom product parts ("Product"), at the original installation site, for a period of Three (3) years from date of purchase (whether directly from Aston Global or an authorized reseller) that the Product manufactured by Aston Global is free from manufacturing defects in materials and workmanship, when used under normal conditions and when such Product has not been modified or changed in any manner after leaving Aston Global's warehouse or plant. If any Product manufactured by Aston Global is found to have manufacturing defects in materials or workmanship, such Product will be repaired or replaced by Aston Global. This warranty applies only against defects discovered within the warranty period and extends only to the original purchaser of the Product. Parts repaired or replaced under the terms of this Warranty will be warranted for the remainder of the original warranty period only.

Proof of purchase is required to exercise this Warranty. Aston Global may, at its option, examine and inspect the alleged defective Product, and Aston Global may request that parts be returned to Aston Global at Owner's expense for factory inspection. The determination as to whether Product shall be replaced, or in the alternative, repaired, shall be made solely by Aston Global. If a Product is determined to be covered by the above Warranty, Aston Global will ship the replacement part(s) to Customer by either ground shipping or US postal service. Increased costs for expedited delivery, if requested by Customer, are the responsibility of Customer. Parts not currently in stock may require up to a 6 week delivery time after placement of order.

**The above warranty is subject to the following conditions: (1) the Product must have been installed by a plumber and electrician licensed by the state in which installation is performed; (2) the Product must be installed in a single family dwelling unit where the original purchaser of the Product resides; and (3) the Product must be maintained as described in the owner's manual supplied with the Product.**

**For glass and acrylic panels, the customer must (a) open and inspect the Product upon delivery (without releasing the delivery driver until visual**

**verification that the Product arrived in a good and acceptable condition); and (b) clearly notate damage on the delivery acknowledgment receipt. Failure to do so, and any damage discovered to glass or acrylic panel after delivery, will be repaired or replaced at the sole discretion of Aston Global.**

**THIS WARRANTY DOES NOT COVER:**

- 1. Product installed in buildings other than single family dwelling units.**
- 2. Product installed outdoors or any other non-standard bathroom location.**
- 3. Component parts not manufactured by Aston Global.**
- 4. Workmanship of any installer of Aston Global Product. This warranty does not assume any liability of any nature for unsatisfactory performance caused by improper installation, or any damages to property resulting from improper installation or use of the Products, including but not limited to flooring, subfloor, tile, walls, sheet rock, concrete board, paint, plumbing fixtures and ceilings.**
- 5. Labor costs incurred in the removal, disassembly, reassembly, or installation of the Product(s), including replacement Products issued under the Warranty, or costs for transportation to Aston Global, and any other materials necessary to return Product to Aston Global.**
- 6. Any Product that has been damaged as a result of being improperly serviced or operated, including, but not limited to, the following: operated with insufficient water; allowed to freeze; subjected to flood conditions; operated with water conditions or additives which cause unusual deposits or corrosion in or on the Product, or subject to any other abuse or negligence.**
- 7. Any Product that has been damaged as a result of natural disasters, including, but not limited to, lightning, fire, earthquake, hurricanes, tornadoes or floods.**
- 8. Product used for any purpose other than residential bathroom usage.**

**LEGAL DISCLAIMERS**

**ALL IMPLIED WARRANTIES, INCLUDING WARRANTIES OF MERCHANTABILITY AND FITNESS FOR A PARTICULAR PURPOSE, ARE HEREBY DISCLAIMED IN THEIR ENTIRETY WITH RESPECT TO ALL PURCHASERS OR OWNERS. FAILURE TO RETURN THE WARRANTY CARD SHALL HAVE NO EFFECT ON THE DISCLAIMER OF THESE IMPLIED WARRANTIES. ALL EXPRESS WARRANTIES SHALL BE LIMITED TO THE DURATION OF THIS EXPRESS LIMITED WARRANTY AND EXCLUDE ANY LIABILITY FOR CONSEQUENTIAL OR INCIDENTAL DAMAGES RESULTING FROM THE BREACH OF ANY EXPRESS WARRANTY. Some states do not**

**allow the exclusion or limitation of incidental or consequential damages, so the above limitations or exclusions may not apply. No dealer, distributor, service company or other party is authorized to change, modify or extend the terms of this warranty in any manner whatsoever.**

**Aston Global and its representatives shall not be liable for any injury, loss, cost or other damages, whether incidental or consequential, arising out of any defect covered by this Warranty including and without limitation, loss of use of the Product and cost for removal of defective Product, even if Aston Global has been advised of the possibility of such damage. The liability of Aston Global under this Warranty, if any, shall not exceed the original amount paid for the Product covered by the Warranty. Coverage under this Warranty shall commence as of the original date of purchase and the duration of such coverage shall not extend for any reason whatsoever beyond the stated time period. The Customer is required to provide adequate access to the Product for any repair or inspection. Aston Global shall not be liable for expenses or damage which may include but are limited to water damage, removal of any and all common building products such as tile, flooring, wood, sheet rock, plumbing fixtures, concrete board, vanities, bathtubs and toilets or any other custom items.**

**THIS WARRANTY GIVES YOU SPECIFIC LEGAL RIGHTS AND YOU MAY HAVE OTHER RIGHTS WHICH VARY FROM STATE TO STATE. ASTON GLOBAL'S FAILURE TO ENFORCE ANY TERMS OR CONDITIONS STATED HEREIN SHALL NOT BE CONSTRUED TO BE A WAIVER OF SUCH PROVISION.**

**For prompt service, notify the original installer who, in turn, will notify the Aston Global distributor who supplied the Product. If this does not result in prompt service, contact Aston Global, Inc. at the address below with details in support of the warranty claim. For any questions about coverage of this Warranty, contact Aston Global at the address below.**

**Aston Global offers free phone support for the life of the Product to the original Owner.**

**The Warranty applies only to Products manufactured on or after January 1, 2011.**

**This Warranty may not be combined with any other warranty offered by Aston Global.**



**Customer Service  
877-424-9699**

**Aston Global Inc  
1501 10th St Suite 150  
PLANO, TX 75074**

**If further assistance is needed, or you  
have a question, please visit our web  
site at:  
[www.astonglobalinc.com](http://www.astonglobalinc.com)**