

Reed™ Technical Specification

Paper Holder

DN1008

Stock Numbers:

- q **DN1008CH – Pivoting Paper Holder**
Chrome Finish
- q **DN1008NLBN – Pivoting Paper Holder**
Brushed Nickel & Polished Nickel Finish

Dimensions:

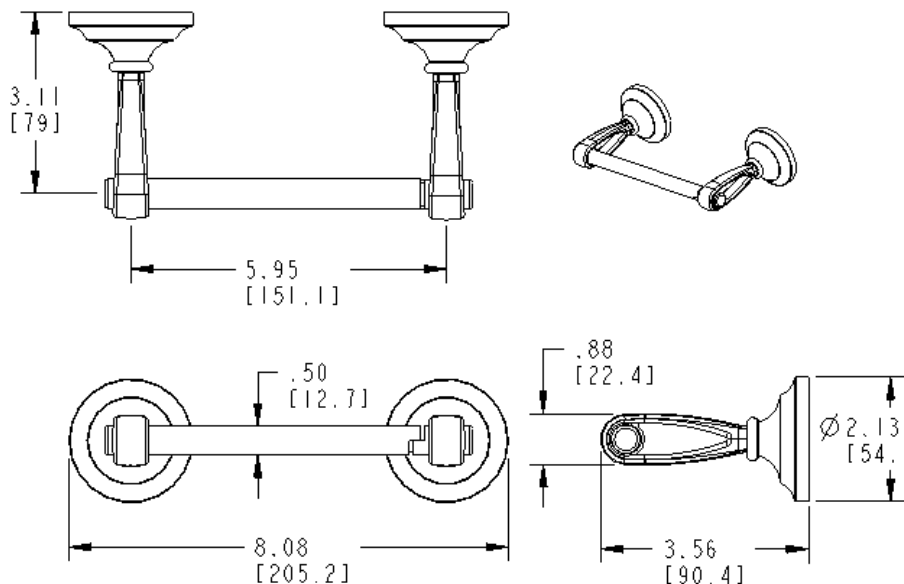

Materials:

Paper Holder is constructed of zinc.

Installation Instructions:

1. Position the mounting template on the wall in the desired location. Using a level, align the template and tape it to the wall.
2. Place each metal bracket over the template.
3. One at a time, place each anchor screw through the bracket, centered in the hole. Using a Phillips screwdriver, turn the anchor screw while applying pressure. Screw will self drill and tap into drywall.
4. Only insert screw 1/2" to 3/4" into wall.
5. After all screws are installed, tear the template away from the wall.
6. Tighten all 4 of the screws. Do not over tighten.
7. Place each post over the mounting plate (setscrew down), pivoting post with bar to be on left side. Tighten both setscrews.

Cleaning Instructions:

To preserve the fine finish of this product, clean only with a soft damp cloth. Dry well. Do not use commercial or abrasive cleaners.

Stock Number: _____ **Paper Holder**
By Creative Specialties



25300 AL MOEN DRIVE • NORTH OLMS TED, OH 44070
CORPORATE HEADQUARTERS: (800) 321-8809 • FAX: (800) 848-6636
INTERNATIONAL: (440) 962-2000 • FAX: (440) 962-2726
CUSTOMER SERVICE (USA): 800-882-0116 • FAX: (888) 379-2720

©Copyright Creative Specialties International 2003

Literature #BA1178