

A502 & A510 PAPER PAD EASEL

PAPER PAD DIMENSION: 27" X 34"
HOLE SPACING: 17-1/2"

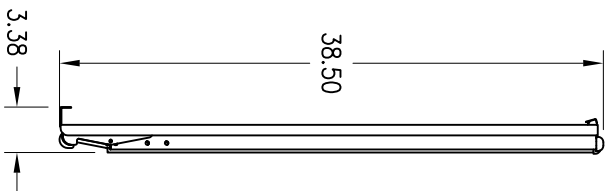

FOLDED VIEW

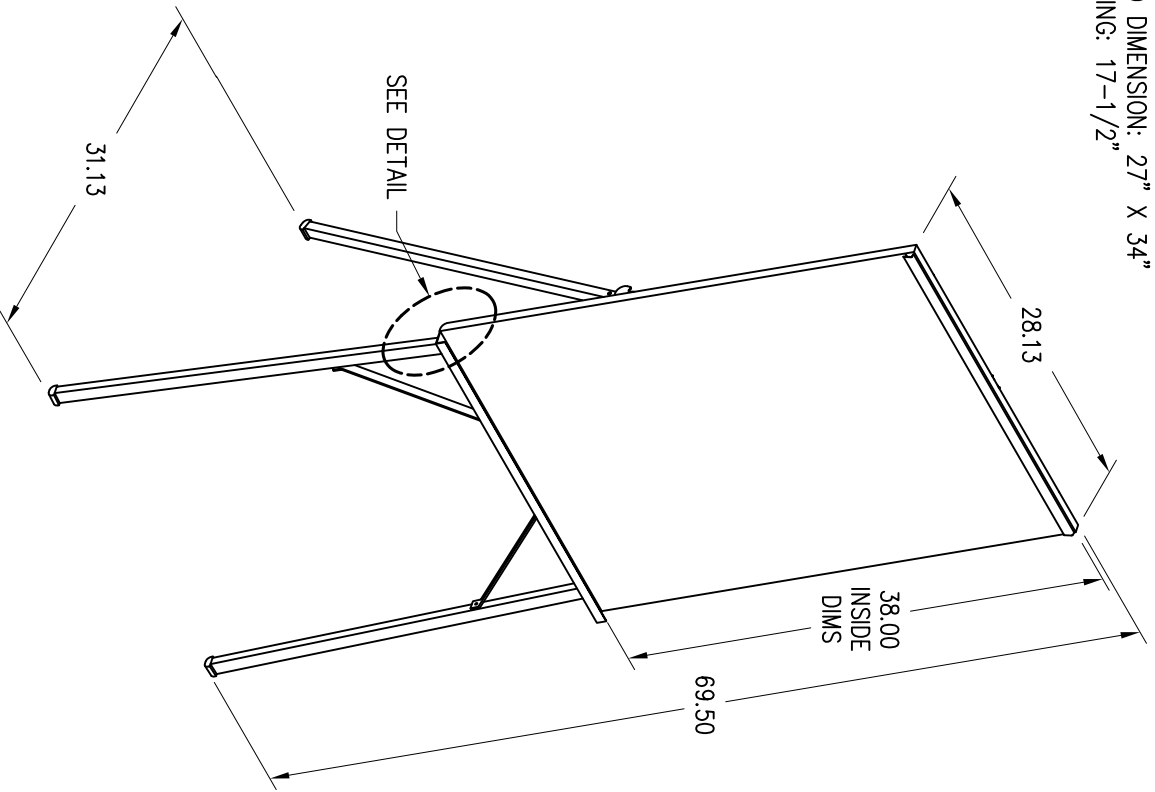
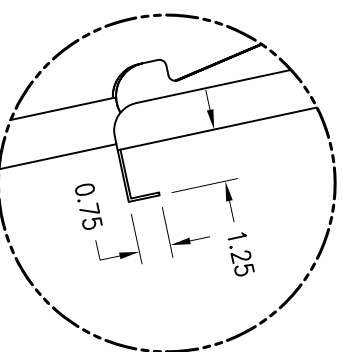

CHALK TRAY DETAIL

THE
Advance
PRODUCTS COMPANY
1199 E. Central, Wichita, KS 67214-3922 Ph: (316) 263-4231

THIS DRAWING IS THE PROPERTY OF THE ADVANCE PRODUCTS COMPANY AND IS NOT TO BE REPRODUCED OR USED TO FURNISH INFORMATION FOR MAKING DRAWINGS EXCEPT WHERE PROVIDED BY AGREEMENT WITH SAID COMPANY.

