

WMAAB Concrete Anchor Bolts

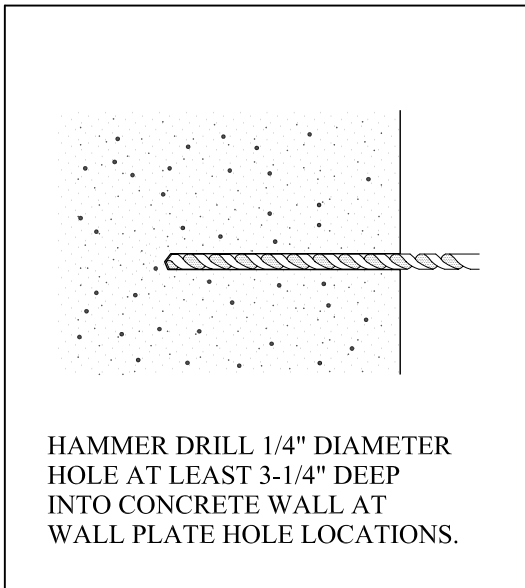

HAMMER DRILL 1/4" DIAMETER HOLE AT LEAST 3-1/4" DEEP INTO CONCRETE WALL AT WALL PLATE HOLE LOCATIONS.

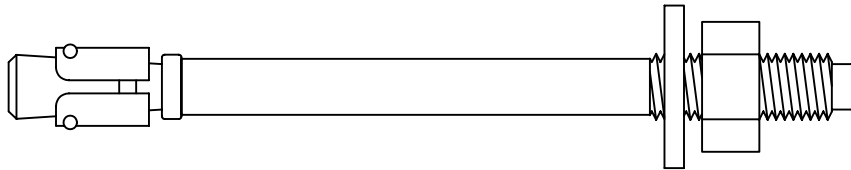
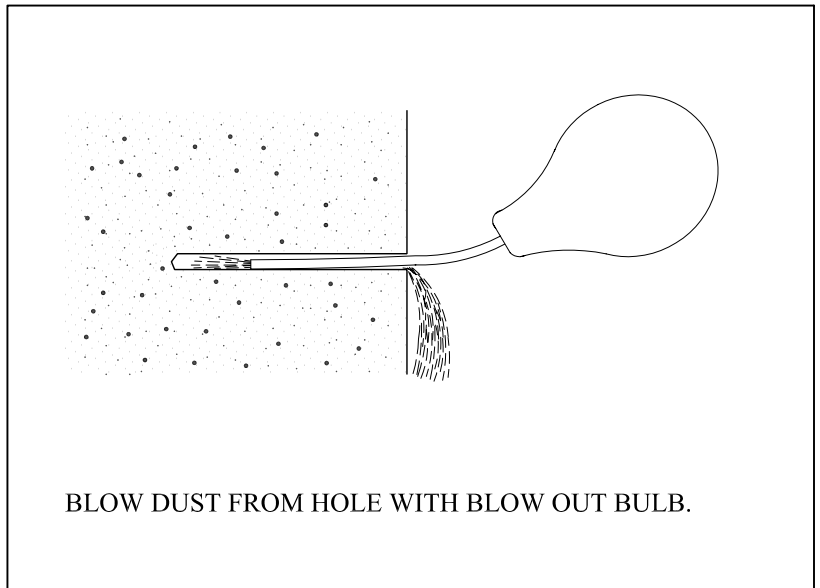

BLOW DUST FROM HOLE WITH BLOW OUT BULB.

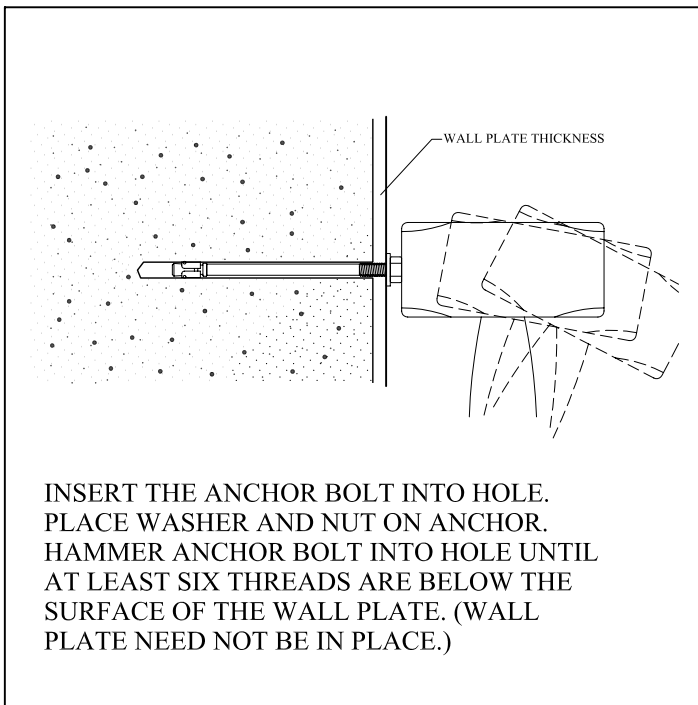

INSERT THE ANCHOR BOLT INTO HOLE. PLACE WASHER AND NUT ON ANCHOR. HAMMER ANCHOR BOLT INTO HOLE UNTIL AT LEAST SIX THREADS ARE BELOW THE SURFACE OF THE WALL PLATE. (WALL PLATE NEED NOT BE IN PLACE.)

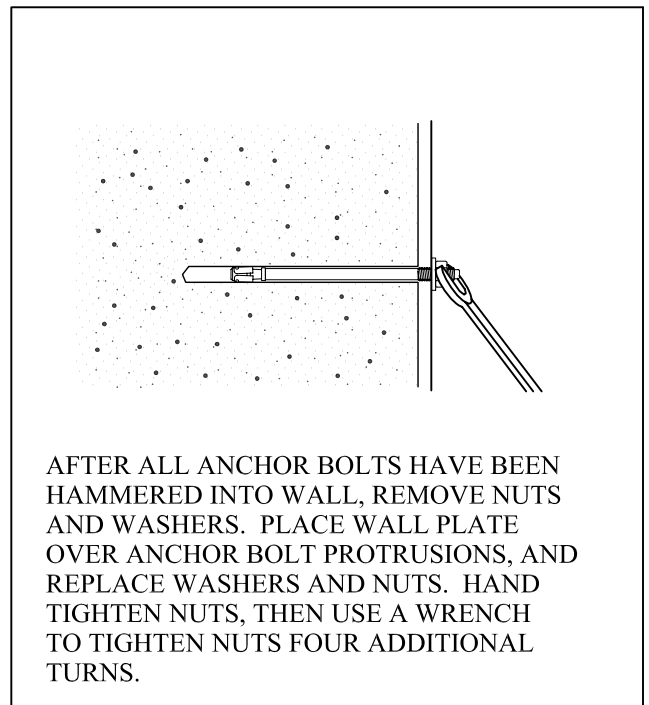

AFTER ALL ANCHOR BOLTS HAVE BEEN HAMMERED INTO WALL, REMOVE NUTS AND WASHERS. PLACE WALL PLATE OVER ANCHOR BOLT PROTRUSIONS, AND REPLACE WASHERS AND NUTS. HAND TIGHTEN NUTS, THEN USE A WRENCH TO TIGHTEN NUTS FOUR ADDITIONAL TURNS.